

AERZEN SCREW COMPRESSORS

Aerzen screw compressor packages DELTA SCREW as compact units,
available in two pressure ranges with optimized power consumption

Pressure range 1 up to 3.0 bar (a) VML 18 R to VML 250

Pressure range 2 up to 4.5 bar (a) VM 8 R to VM 140
with gearbox or belt drive



AERZEN

**AERZENER MASCHINENFABRIK
GMBH**

V1-018 | 06 | EN

3000

5.2005

Technical progression

The Aerzener Maschinenfabrik GmbH has been manufacturing Screw Compressors since 1943. As the Market Leader in Europe, the company is one of the oldest and largest manufacturers of Roots Blowers and Screw Compressors. Technical expertise, experienced staff and a permanent dialogue with the customers all help to maintain the lead in technology now and for the future.

The further development and introduction of the new DELTA SCREW Packages is an answer to the rising demands of our customers and the increasing demands of the future market.

Application fields and use

The units are specifically designed to match practical requirements in the field. They are the ideal solution for the dry, oil-free and clean compression of air and neutral gases as required e.g. in the following application fields:

- pneumatic conveying with air or nitrogen
- aeration of sewage basins
- homogenising of cement
- vacuum production in the glass industry
- prevention of ice build-up in harbours and lakes
- oil booms
- gas-air mixing plants
- oxidation air for power stations
- stationary unloading of silo vehicles
- vacuum production in the paper industry
- conveying and compression of neutral gases
- blast air for production of spunbonded web



All DELTA SCREW-units can be delivered with ATEX 100 A - certification on customers request.



General

Single-stage Aerzen screw compressors are manufactured as air-cooled units for intake volumes from 200 to 15.000 m³/h. Discharge pressures of up to $p_2 = 3.0$ bar and 4.5 bar abs., dry, oil-free compression, temperature limit t_2 maximum 250 °C. Vacuum operation is possible with the standard VML-compressors to a maximum of 70% (0.3 bar abs.) and as a modified unit to 85% (0.15 bar abs.).

Driving shaft

sealed by peak seals, working maintenance-free in combination with a well-aimed oil-chamber release.

Energy consumption

Depending on the maximum discharge pressure 3+4 or 4+6 screw profiles are used. This results in an optimum use of energy despite other influences such as tolerances, pressure losses at accessories and deflections of the volume flow.

Large or small performances

With all units of the DELTA SCREW series, rotor profile, internal compression ratio and accessories can be optimized to meet individual requirements.

Technology

DELTA SCREW units are delivered complete with internal installation, piping and wiring, and are ready for connection to the customer's system.

By using a frequency converter the volume can be regulated over a large range with a ratio of approximately 1:4. Relatively small rotor diameters and low risk of internal contamination preclude any additional imbalances that could increase vibration.

Even under difficult operating conditions the calculated bearing lifetime is > 40.000 hours

Adaptability

Depending on customer requirements the scope of supply can include for example:

- Driving motor
- Control - and power cabinet
- Acoustic hood
- Start-up unloading device
- Full load / idle running system.

Simple operation

All operation and maintenance elements are accessible from one side, this includes instrument panel, oil filter, oil level sight glasses, air - and oil filters and therefore enable a simple operation and maintenance.

Chassis

The base frame for the compressor stages with belt drive has several functions. It is base support for the compressor stage, suction-silencer and oil reservoir in one. That reduces costly installation surface.

Ranges of pressure

In overpressure two discharge pressure ranges are available.

VML up to 3,0 bar (a) VM up to 4,5 bar (a)

In vacuum pressure:

VML up to 0,3 bar (a)

up to 0,15 bar (a) with pre-inlet

Efficiency

During the whole operating period of the compressor the efficiency remains virtually constant so that no reduction of the conveying capacity will occur.

With belt drive

The belt drive of DELTA SCREW - units is designed so that v-belt tension is constant in all operating conditions. The weight of the motor mounted on a hinged support ensures that the tension of the v-belts is always as it should be.



Compression process

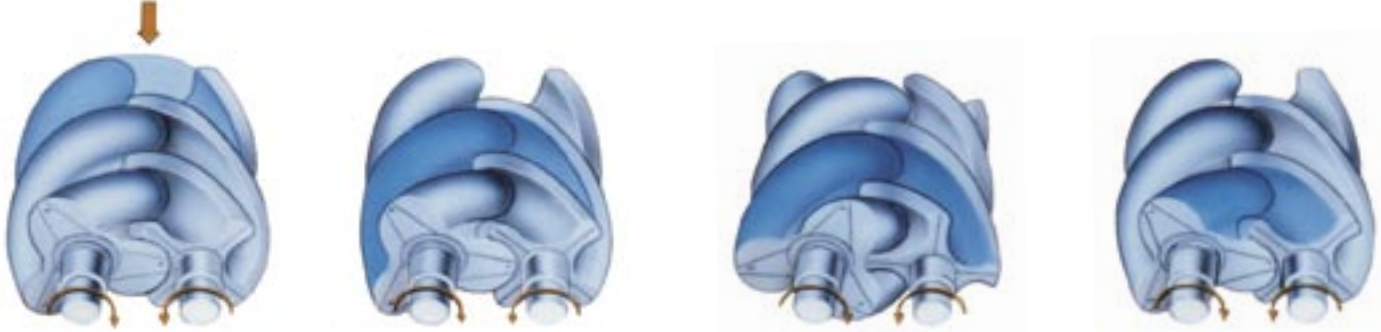

Suction

The gas enters through the inlet opening into the open thread of the rotors.

Compression process

By progressing rotation of the rotors the inlet opening is closed, the volume reduced, the pressure increases.

Discharge

The compression is finished, the discharge pressure achieved, the discharge starts.

Installation

The packages are delivered completely assembled, allowing their prompt and trouble-free installation. Installation procedures at site are limited to the connection of the power supply and plant piping resp. filling-up of oil. The standard package designed for pressure mode operation sucks in ambient atmospheric air through a filter. In vacuum mode and nitrogen operation, the intake filter is substituted by a suction silencer or pipe connection. An additional expansion joint with tie-rods ensures stress-free intake connection to plant piping. The standard package is designed to accept motors having IP 55 type protection.

In the case of packages equipped with an acoustic hood, the electrical wiring as well as the motor starter and pushbuttons can be installed in the standard instrument panel. (only applies for machines with gearbox).

Drive

The compressor is normally driven via an electric motor of B 3 design. Other drive configurations (e.g. diesel motor, turbine) are available upon request. When installing an acoustic hood, the following must be considered: - The fan is designed to provide sufficient cooling to maintain a maximum temperature rise within the hood of 10 °C. - The amount of the heat radiated from the compressor package surfaces represents approx. 25 % of the drive power, depending on the particular operating conditions and compressor size. However, some higher heat radiation values can be reached where machines are equipped with an intake throttling regulation valve.

The internal pressure losses across the hood amount to max. 100 N/m². - The ventilation of the acoustic hood is carried out by a mechanically driven fan, which is mounted to an extension of the driving shaft (VML 150/250 electrically driven).



Unit

Concerning the Delta Screw units there is always a standardized concept for the package.

Two variants are possible:

1. Drive of the compressor stage directly via an integrated gearbox.

Arrangement of compressor stage and driving motor one behind the other, installed on a common base frame.

2. Drive of the compressor stage via belt drive.

Arrangement of compressor stage and driving motor side by side, hinged motor plate fixed laterally on the body of the compressor.

Start-up, regulation

As an option the VML-compressors can be provided with a self-controlled start-up unloading device. Upon request, VM-compressors can be supplied with an idling / full load regulation system, e.g. to unload the compressor in the case of star-delta starting, or to reduce energy consumption during intermittent operation (for star-delta starting, please consult the manufacturer first).

Construction and design (compressor stage)

Rotors:

Profile VML: 3 + 4, VM: 4 + 6, asymmetric dynamically balanced according to DIN ISO 1940 T1, quality G = 2.5

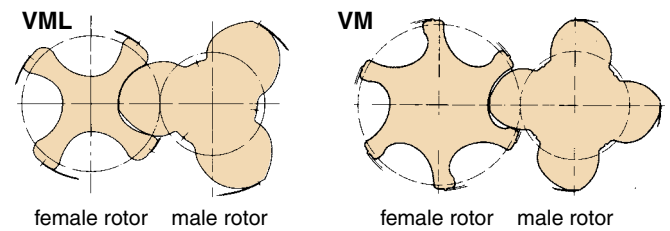

Sealings:

VM: conveying chamber: carbon ring labyrinth sealing at suction- and discharge side with chamber rings and neutral chamber.

Driving shaft: peak seal

VML: conveying chamber: piston rings at suction side, carbon ring labyrinth sealing at discharge side, each with neutral chamber.

Driving shaft: peak seal

Materials:

housing: grey cast GG 25

rotors: steel C 45 N

sealings: Ek 305, steel / carbon

gear wheels: hardened steel

Bearings:

Roller bearings with integrated forced-feed lubrication.



Construction and design (Drive and oil system)

Belt drive:

Drive

Heavy-duty narrow V-belt, continuous belt tension due to motor weight

Oil system

- oil reservoir integrated in the base frame
- oil overflow valve
- oil pump driven by female rotor, accessible from the outside
- oil cooling as oil-/air cooler incl. oil temperature regulating valve (limited to 90 °C), aeration via mechanical fan on the driving shaft (applies starting from 40 °C intake temperature, cooler block installed on belt guard / hood ventilation)
- oil filter as screw-down filter
- oil chamber relief via oil demister, installed on the compressor stage



Gearbox:

Drive

Step-up gearbox integrated on the intake side with closely stepped gear ratios

Oil system

- oil reservoir integrated in the compressor housing
- oil overflow valve
- oil pump driven by female rotor, accessible from the outside
- oil cooling as oil-/air cooler incl. oil temperature regulating valve (limited to 90 °C), aeration via mechanical fan on the driving shaft (cooler block integrated in compressor stage)
- oil filter as screw-down filter
- oil chamber relief via oil demister, installed on the compressor stage



Instrumentation and controls

The instrumentation panel indicates and controls the following functions:



VML / VM

Visual maintenance indicator in case of contamination of the air intake filter with additional protection by means of electrical pressure switches for suction pressure, discharge pressure and oil pressure discharge temperature and oil temperature.

The switches are wired internally on the terminal strip. Extension of instrumentation acc. to design VM is possible (option).

All sensing points are monitored by an electronic fault indication device featuring „first-out” indication. Instrumentation to meet special requirements (e.g. ex-proof) is available upon request.

Alternatively for VM and VML:

Aerzen Universal Control Unit including instrumentation in analog technique with pressure transmitter for suction-, discharge- and oil pressure. Resistance thermometer for discharge- and oil temperature.

Indications are optionally (multi-lingual) available in the display.

Control options for all possible cases of operation. Indication of the service intervals.

Limit value recording

as fault indication archives. Serial interface (RS 485) for data transmission (e.g. telediagnostic service, linkage of several machines among each other).

(Design not ex-proof).



Scope of supply and performances

The scope of supply of a DELTA SCREW compressor unit made by Aerzener for air operation (basic unit) includes the following items:

Belt drive

- Aerzen Screw compressor stage with reinforced bearing of the driving shaft (female rotor) suitable for belt drive. Forced-feed lubrication including oil pump, oil filter, oil return flow valve, turbo filter for oil chamber release.
- Base support as suction silencer with hinged motor plate (three-phase current motor)
- Intake filter (single-stage) integrated in the base frame
- Belt drive with guard

Gearbox

- Aerzen Screw compressor stage with integrated step-up gearbox, forced-feed lubrication including oil pump, oil filter, oil return flow valve, air/oil cooler, turbo filter for oil chamber release.
- Base support for compressor stage and driving motor (three-phase current motor)
- Intake filter (double-stage) with intake manifold
- Flexible coupling with guard

Items also belonging to the basic unit: (applies for belt drive and gearbox)

- Discharge silencer
- Safety relief valve (type-tested)
- Non-return valve
- Expansion joint with tie-rod, discharge side
- Flexible machinery mountings with anchor bolts
- Instrument panel for protection of the machine with indication and monitoring for suction-, discharge- and oil pressure, discharge- and oil temperature, single-fault indication and operating hour meter

Extended scope of instrumentation same as for VM possible even for VML against extra price.

Accessories: Options (belt drive and gearbox)

- Driving motor as three-phase current motor including assembly in Aerzen
- Acoustic hood for the complete compressor unit for indoor and outdoor installation
- Start-up unloading valve for VML-compressors (self-medium controlled)
- Constant-speed unloading device for VM-compressors including suction throttle, relief valve and pressure switch PSLH (self-medium controlled)
- switch cabinet with electrical interconnection (e.g. star-delta)
- Frequency converter, designed as separate cabinet (installation and external wiring at site)
- Overflow-regulating valve (self-medium controlled) for keeping the discharge pressure or vacuum constant, loose supply, for installation into the pipe provided at site
- separate after-cooler, loose supply, for installation into the pressure pipe provided at site, designed as air-/air cooler or air-/water cooler, in case of danger of condensation on request even with cyclone separator and automatic drain.

Modifications: Options (belt drive and gearbox)

- Nitrogen design including suction silencer, starting strainer, expansion joint suction side, suction pressure gauge
- Ex-proof design with intrinsically safe instrumentation, main- and aux. drives in EEx e or EEx de
- Special instrumentation in co-ordination with the customer's specification
- Deviating finish
- ANSI-flanges at battery limit
- Vacuum design (even with pre-inlet) incl. suction silencer, starting strainer, expansion joint suction side, suction pressure gauge, suction valve, vacuum filter as option



Flow diagram VML-R (belt drive)

1. air filter monitoring
2. intake pressure switch
3. contact thermometer (discharge temperature)
4. contact thermometer (oil temperature)
5. discharge pressure gauge
6. discharge pressure switch
7. oil pressure gauge
8. oil pressure switch
9. oil level sight glass
10. intake filter
11. compressor stage
- 11a. sound-absorbing connection chamber
12. discharge silencer
13. check valve
14. expansion joint
15. safety relief valve
16. oil pump
19. oil filter
20. oil overflow valve
21. oil drain valve
22. oil demister
32. belt drive
33. suction silencer

The following items are not included in the standard scope of supply and are available at extra costs:

28. relief valve
30. acoustic hood with fan
31. electric motor

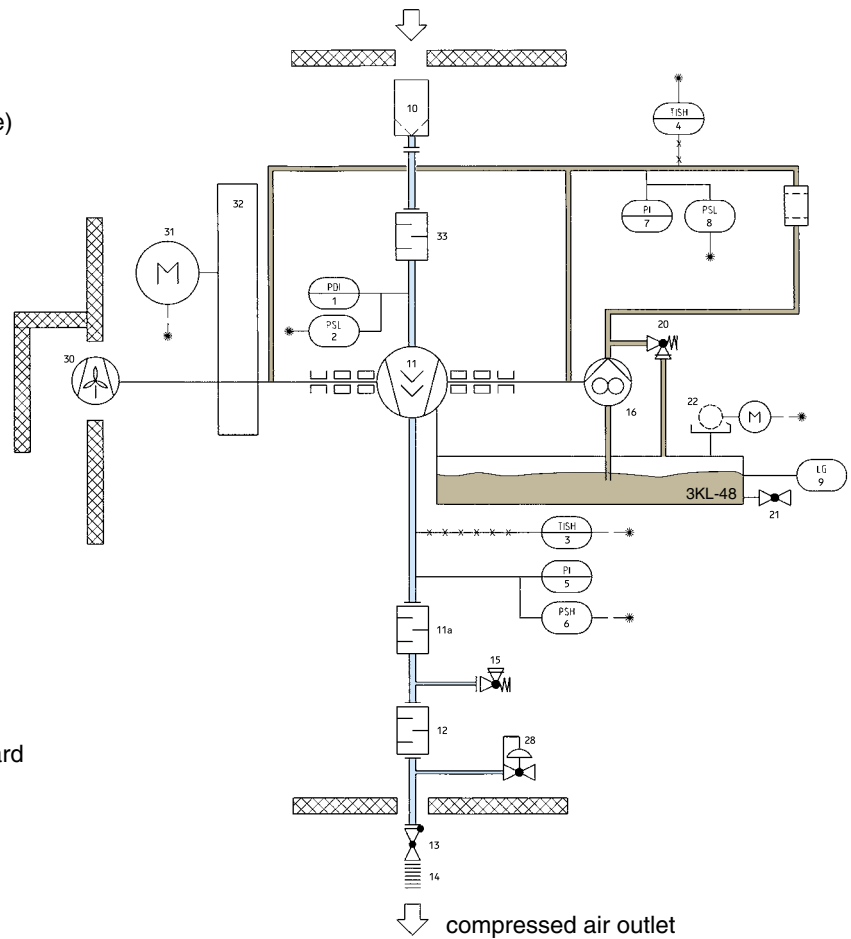

Flow diagram VM-R (belt drive)

1. air filter monitoring
2. intake pressure switch
3. contact thermometer (discharge temperature)
4. contact thermometer (oil temperature)
5. discharge pressure gauge
6. discharge pressure switch
7. oil pressure gauge
8. oil pressure switch
9. oil level sight glass
10. intake filter
11. compressor stage
12. discharge silencer
13. check valve
14. expansion joint
15. safety relief valve
16. oil pump
18. oil air cooler
19. oil filter
20. oil overflow valve
21. oil drain valve
22. oil demister
32. belt drive
33. suction silencer

The following items are not included in the standard scope of supply and are available at extra costs:

30. acoustic hood with fan
31. electric motor
23. intake pressure gauge
24. pressure switch
25. throttle flap regulation
26. 3-way solenoid valve
27. pressure selection relay
28. relief valve

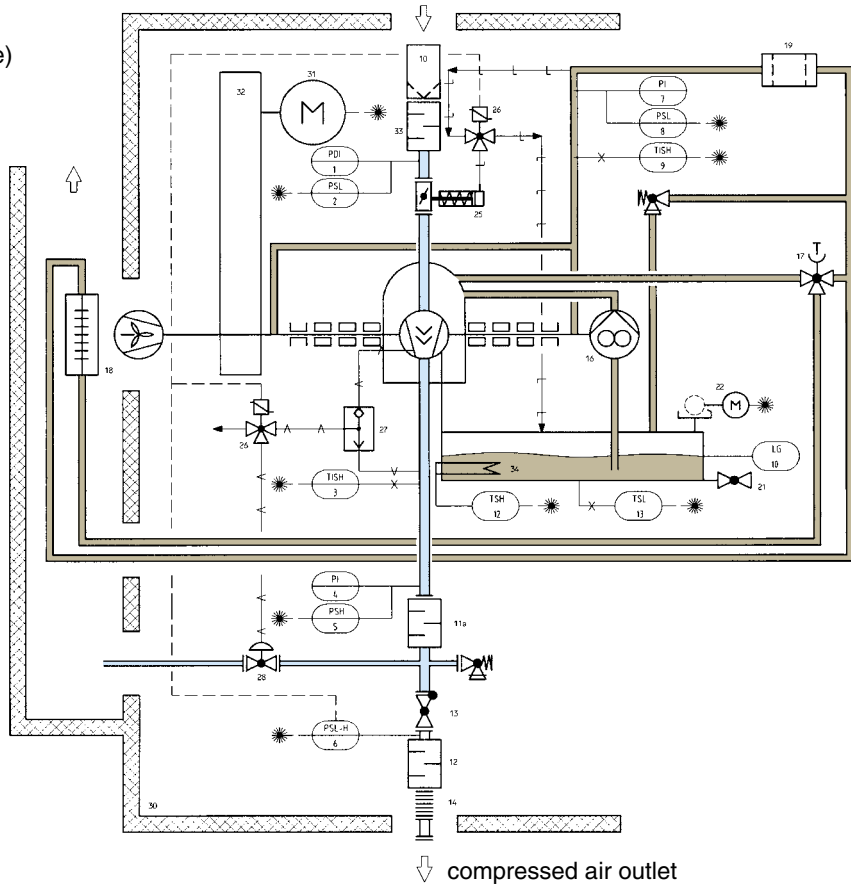

Flow diagram VML... with start-up unloading device

1. air filter monitoring
2. intake pressure switch
3. contact thermometer (discharge temperature)
4. contact thermometer (oil temperature)
5. discharge pressure gauge
6. discharge pressure switch
7. oil pressure gauge
8. oil pressure switch
9. oil level sight glass
10. intake filter
11. compressor stage
12. discharge silencer
13. check valve
14. expansion joint
15. safety relief valve
16. oil pump
17. oil temperature regulator
18. oil air cooler *
19. oil filter
20. oil overflow valve
21. oil drain valve
22. oil demister

The following items are not included in the standard scope of supply and are available at extra costs:

25. electric motor
28. start-up unloading device
30. acoustic hood with fan *

* For VML 150/ 250 electrically driven

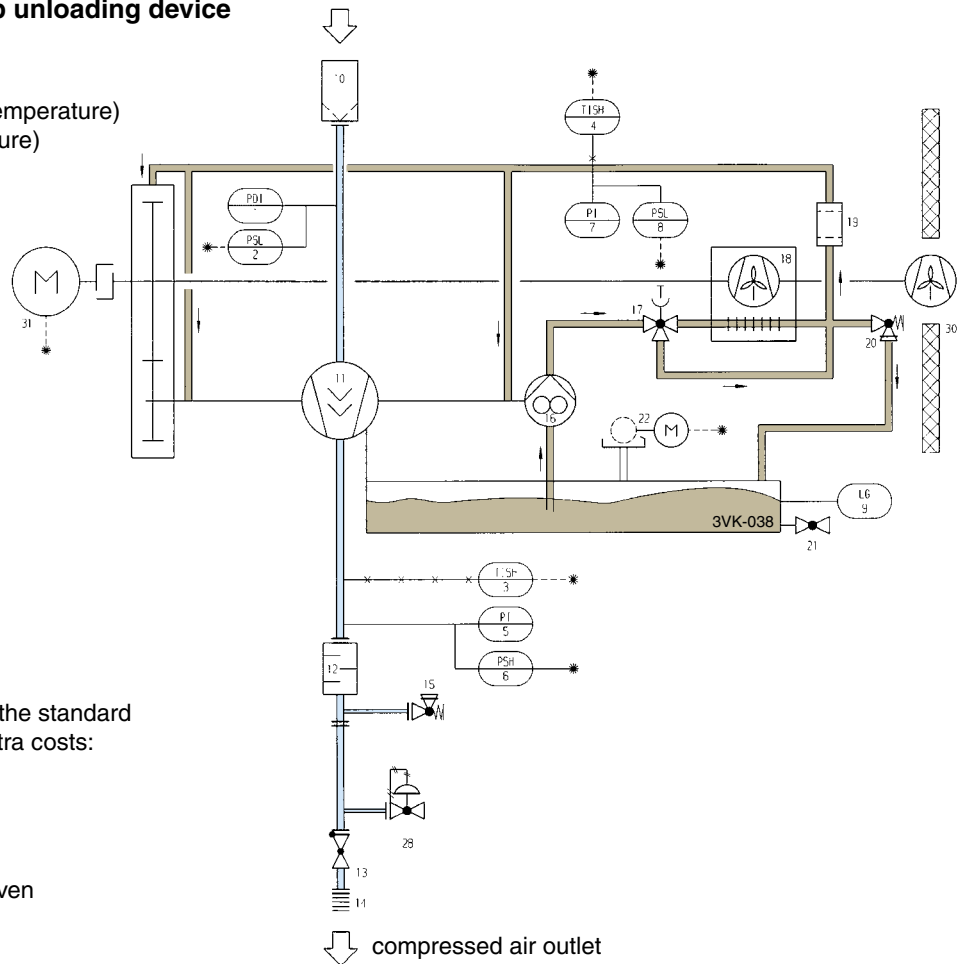

Flow diagram VM... with regulation

1. air filter monitoring
2. intake pressure switch
3. contact thermometer (discharge temperature)
4. contact thermometer (oil temperature)
5. discharge pressure gauge
6. discharge pressure switch
7. oil pressure gauge
8. oil pressure switch
9. oil level sight glass
10. intake filter
11. compressor stage
12. discharge silencer
13. check valve
14. expansion joint
15. safety relief valve
16. oil pump
17. oil temperature regulator
18. oil air cooler
19. oil filter
20. oil overflow valve
21. oil drain valve
22. oil demister

The following items are not included in the standard scope of supply and are available at extra costs:

30. acoustic hood with fan
31. electric motor
23. intake pressure gauge
24. pressure switch
25. throttle flap regulation
26. 3-way solenoid valve
27. pressure selection relay
28. relief valve
29. blow-off silencer

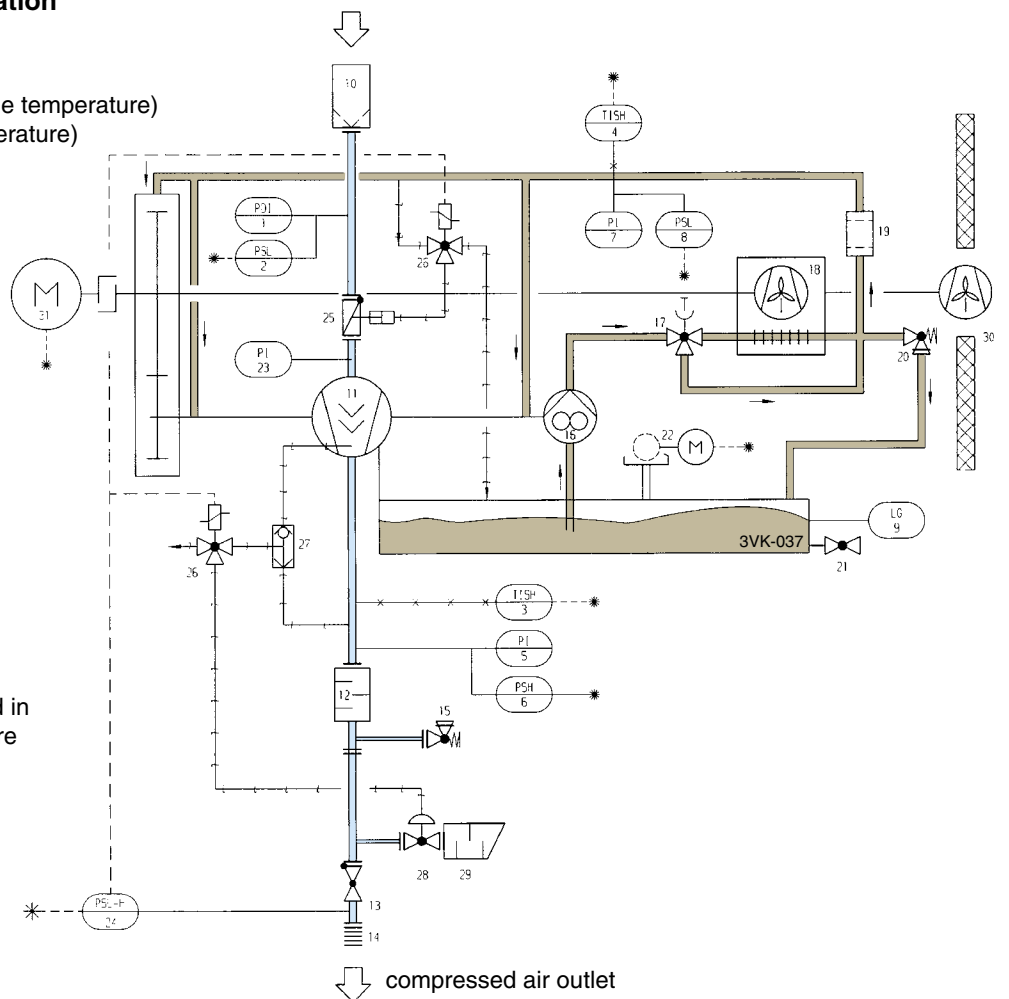

Noise data

The sound frequency analysis in 1/1 octave bands was carried out on a VM 21 R package.
 Measurements in free field, at a distance = 1.0 m.
 Measuring height = 1.5 m
 Discharge pressure $p_e = 3.5$ bar
 $n_{mot} = 2950$ rpm
 Step-up gear ratio B_7

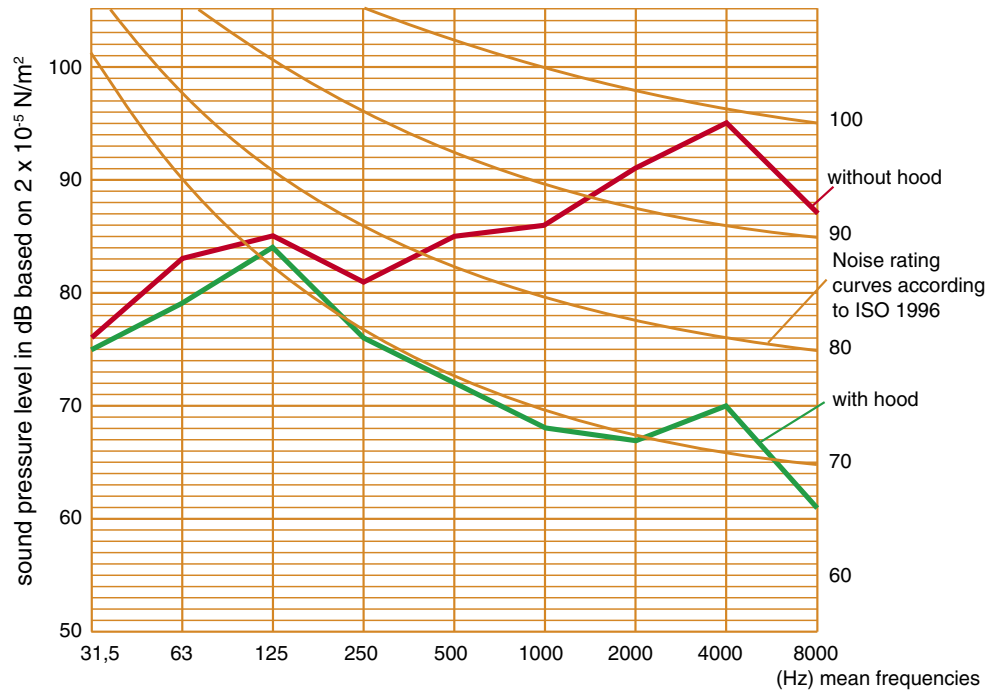

Using the performance charts

We always distinguish

1. in drive mode belt drive or gearbox
2. in discharge pressure

For performance data up to 2 bar overpressure

⇒ VML-compressors

For performance data up to 3,5 bar overpressure

⇒ VM-compressors

The performance charts are in chronological order according to compressor sizes. First it has to be decided which drive mode is preferred.

To distinguish the type designations the belt driven machines end with an “R” concerning their designation.

The performance charts have the same structure.

Depending on compressor type the possible performance data were entered in the corresponding chart (in the upper section up to 2 bar applicable for compressor types VML, in the lower section up to 3,5 bar applicable for compressor types VM).

The volume flow increases from the left to the right side. We are always trying to use the smallest-possible machine.

The applicable performance data of the corresponding case of operation result from “column” (referring to the volume flow) and “line” (referring to the requested discharge pressure).

Explanations:

Sum of the individual moments of inertia of compressor, gearbox and coupling, based on the drive speed.

$$J_{\Delta} \frac{GD^2}{4}$$

p_1 intake pressure (abs.)

t_1 intake temperature

p_e discharge pressure, gauge

i_1 to i_{14} standard gear ratios

In order to meet the requested volume flow even more closely, intermediate gear ratios are available between each standard ratio, e.g. $i_{9/10}$ between i_9 and i_{10} .

L_p (A) o.H./m.H. sound pressure level as machine noise acc. to DIN 45635 - without hood / with hood.

The data applicable to intermediate step-up gear ratios can be interpolated, as in these ranges the operating data are of linear relationship and can be calculated proportionally.

The data shown are based on the compression of air at $p_1 = 1,0$ bar and $t_1 = 20$ °C. Data concerning deviating suction conditions, vacuum operation, compression of gas and multi-stage compression configurations are available on request.

The fan power for acoustic hood depends on the particular operating conditions.

Oil demister operating requirements: 0,37 kW

50 m³/h

3000 rpm.

Our sales department shall be at your disposal at any time concerning questions on the necessary equipment and possibilities of application.

Performance data based on the compression of air ($p_1 = 1.0 \text{ bar}$, $t_1 = 20 \text{ }^\circ\text{C}$)

Discharge pressure p_2 [bar gauge]	Compressor size		VM 8 R									
	belt drive ratio		B	B_6	$B_{6/7}$	B_7	$B_{7/8}$	B_8	$B_{8/9}$	B_9	$B_{9/10}$	B_{10}
0,75	flow at inlet	V_1	[m ³ /h]									
	compressor speed	nH	[1/min]									
	motor speed	nM	[1/min]									
	discharge temperature	t_2	[°C]									
	power at shaft / motor rating	$\dot{P}_{K/Mot}$	[kW]									
	power, idling $p_1 = p_2 = 1,0 \text{ bar}$	P_{Leer}	[kW]									
	reduced moment of inertia Lp(A) w/o.h./w.h.	J	[kgm ²]									
			[dBA]									
1,00	flow at inlet	V_1	[m ³ /h]									
	compressor speed	nH	[1/min]									
	motor speed	nM	[1/min]									
	discharge temperature	t_2	[°C]									
	power at shaft / motor rating	$\dot{P}_{K/Mot}$	[kW]									
	power, idling $p_1 = p_2 = 1,0 \text{ bar}$	P_{Leer}	[kW]									
	reduced moment of inertia Lp(A) w/o.h./w.h.	J	[kgm ²]									
			[dBA]									
1,25	flow at inlet	V_1	[m ³ /h]									
	compressor speed	nH	[1/min]									
	motor speed	nM	[1/min]									
	discharge temperature	t_2	[°C]									
	power at shaft / motor rating	$\dot{P}_{K/Mot}$	[kW]									
	power, idling $p_1 = p_2 = 1,0 \text{ bar}$	P_{Leer}	[kW]									
	reduced moment of inertia Lp(A) w/o.h./w.h.	J	[kgm ²]									
			[dBA]									
1,50	flow at inlet	V_1	[m ³ /h]									
	compressor speed	nH	[1/min]									
	motor speed	nM	[1/min]									
	discharge temperature	t_2	[°C]									
	power at shaft / motor rating	$\dot{P}_{K/Mot}$	[kW]									
	power, idling $p_1 = p_2 = 1,0 \text{ bar}$	P_{Leer}	[kW]									
	reduced moment of inertia Lp(A) w/o.h./w.h.	J	[kgm ²]									
			[dBA]									
1,75	flow at inlet	V_1	[m ³ /h]									
	compressor speed	nH	[1/min]									
	motor speed	nM	[1/min]									
	discharge temperature	t_2	[°C]									
	power at shaft / motor rating	$\dot{P}_{K/Mot}$	[kW]									
	power, idling $p_1 = p_2 = 1,0 \text{ bar}$	P_{Leer}	[kW]									
	reduced moment of inertia Lp(A) w/o.h./w.h.	J	[kgm ²]									
			[dBA]									
2,00	flow at inlet	V_1	[m ³ /h]	287	312	338	366	392	415	441	468	497
	compressor speed	nH	[1/min]	14162	15002	15861	16802	17935	18999	20212	21448	22813
	motor speed	nM	[1/min]	2930	2930	2930	2930	2945	2945	2945	2950	2950
	discharge temperature	t_2	[°C]	167	164	161	159	160	161	163	165	167
	power at shaft / motor rating	$\dot{P}_{K/Mot}$	[kW]	17,5 / 18,5	18,6 / 22	19,8 / 22	21,1 / 22	23,3 / 30	25,6 / 30	28,5 / 30	31,5 / 37	35,2 / 37
	power, idling $p_1 = p_2 = 1,0 \text{ bar}$	P_{Leer}	[kW]	7,3	8,1	8,8	9,8	11,1	12,6	14,4	16,5	18,9
	reduced moment of inertia Lp(A) w/o.h./w.h.	J	[kgm ²]	0,199	0,215	0,254	0,271	0,334	0,356	0,433	0,461	0,579
			[dBA]	89/73	89/73	91/75	93/77	94/78	95/80	95/81	95/82	97/84
2,25	flow at inlet	V_1	[m ³ /h]	282	307	333	364	387	410	436	462	490
	compressor speed	nH	[1/min]	14162	15002	15861	16888	17935	18999	20247	21448	22736
	motor speed	nM	[1/min]	2930	2930	2930	2945	2945	2950	2950	2950	2940
	discharge temperature	t_2	[°C]	183	180	177	174	174	175	177	178	180
	power at shaft / motor rating	$\dot{P}_{K/Mot}$	[kW]	19,1 / 22	20,3 / 22	21,6 / 22	23,1 / 30	25,4 / 30	27,8 / 30	30,9 / 37	34,1 / 37	37,8 / 45
	power, idling $p_1 = p_2 = 1,0 \text{ bar}$	P_{Leer}	[kW]	7,3	8,1	8,8	9,8	11,1	12,6	14,4	16,5	18,9
	reduced moment of inertia Lp(A) w/o.h./w.h.	J	[kgm ²]	0,199	0,214	0,254	0,273	0,334	0,356	0,433	0,461	0,578
			[dBA]	89/73	89/73	91/75	93/78	94/80	95/80	95/81	95/82	97/84
2,50	flow at inlet	V_1	[m ³ /h]	280	307	333	361	382	405	431	456	485
	compressor speed	nH	[1/min]	14162	15078	15942	16888	17935	19031	20247	21375	22736
	motor speed	nM	[1/min]	2930	2945	2945	2945	2945	2950	2950	2940	2940
	discharge temperature	t_2	[°C]	198	194	191	189	189	190	191	192	194
	power at shaft / motor rating	$\dot{P}_{K/Mot}$	[kW]	20,7 / 22	22,2 / 30	23,6 / 30	25,2 / 30	27,4 / 30	30,2 / 37	33,4 / 37	36,5 / 45	40,6 / 45
	power, idling $p_1 = p_2 = 1,0 \text{ bar}$	P_{Leer}	[kW]	10,9	11,9	13	14,5	16,2	18,4	20,8	23,8	27,1
	reduced moment of inertia Lp(A) w/o.h./w.h.	J	[kgm ²]	0,199	0,214	0,256	0,273	0,334	0,356	0,433	0,494	0,636
			[dBA]	89/73	89/73	91/76	93/79	94/81	95/81	95/81	95/82	97/84
2,75	flow at inlet	V_1	[m ³ /h]	277	303	329	357	380	404	430	451	480
	compressor speed	nH	[1/min]	14234	15078	15942	16888	17935	19031	20247	21375	22736
	motor speed	nM	[1/min]	2945	2945	2945	2945	2945	2950	2950	2940	2940
	discharge temperature	t_2	[°C]	213	208	205	201	202	204	205	207	208
	power at shaft / motor rating	$\dot{P}_{K/Mot}$	[kW]	22,3 / 30	23,7 / 30	25,2 / 30	26,9 / 30	29,5 / 30	32,5 / 37	36,1 / 37	39,2 / 45	43,5 / 45
	power, idling $p_1 = p_2 = 1,0 \text{ bar}$	P_{Leer}	[kW]	10,9	11,9	13	14,5	16,2	18,4	20,8	23,8	27,1
	reduced moment of inertia Lp(A) w/o.h./w.h.	J	[kgm ²]	0,201	0,214	0,256	0,273	0,334	0,356	0,433	0,494	0,636
			[dBA]	91/74	91/74	92/76	93/79	94/81	95/81	95/81	96/82	97/84
3,00	flow at inlet	V_1	[m ³ /h]	273	298	324	353	377	399	424	450	482
	compressor speed	nH	[1/min]	14234	15078	15942	16888	17965	19031	20178	21375	22852
	motor speed	nM	[1/min]	2945	2945	2945	2945	2950	2950	2940	2940	2955
	discharge temperature	t_2	[°C]	229	223	219	215	215	216	218	219	221
	power at shaft / motor rating	$\dot{P}_{K/Mot}$	[kW]	23,7 / 30	25,2 / 30	26,8 / 30	28,5 / 30	31,3 / 37	34,4 / 37	37,9 / 45	41,7 / 45	46,8 / 55
	power, idling $p_1 = p_2 = 1,0 \text{ bar}$	P_{Leer}	[kW]	10,9	11,9	13	14,5	16,2	18,4	20,8	23,8	27,1
	reduced moment of inertia Lp(A) w/o.h./w.h.	J	[kgm ²]	0,201	0,214	0,256	0,273	0,334	0,356	0,466	0,494	0,636
			[dBA]	92/75	93/75	93/77	93/79	94/81	95/81	95/81	96/82	97/84
3,25	flow at inlet	V_1	[m ³ /h]	269	294	320	349	372	395	420	446	478
	compressor speed	nH	[1/min]	14234	15078	15942	16917	17965	19031	20178	21375	22852
	motor speed	nM	[1/min]	2945	2945	2945	2950	2950	2950	2940	2940	2955
	discharge temperature	t_2	[°C]	245	238	233	228	229	229	230	231	233
	power at shaft / motor rating	$\dot{P}_{K/Mot}$	[kW]	25,2 / 30	26,7 / 30	28,4 / 30	30,2 / 37	33,1 / 37	36,3 / 37	39,9 / 45	43,9 / 45	49,2 / 55
	power, idling $p_1 = p_2 = 1,0 \text{ bar}$	P_{Leer}	[kW]	10,9	11,9	13	14,5	16,2	18,4	20,8	23,8	27,1
	reduced moment of inertia Lp(A) w/o.h./w.h.	J	[kgm ²]	0,201	0,214	0,256	0,273	0,334	0,356	0,466	0,494	0,636
			[dBA]	94/78	94/79	95/80	95/81	96/82	97/83	97/83	98/84	98/85
3,50	flow at inlet	V_1	[m ³ /h]				345	368	389	415	444	473
	compressor speed	nH	[1/min]				16917	17965	18967	20178	21484	22852
	motor speed	nM	[1/min]				2950	2950	2940	2940	2955	2955
	discharge temperature	t_2	[°C]				242	242	243	243	244	245
	power at shaft / motor rating	$\dot{P}_{K/Mot}$	[kW]				31,9 / 37	34,9 / 37	38 / 45	42 / 45	46,5 / 55	52 / 55
	power, idling $p_1 = p_2 = 1,0 \text{ bar}$	P_{Leer}	[kW]				14,5	16,2	18,4	20,8	23,8	27,1
	reduced moment of inertia Lp(A) w/o.h./w.h.	J	[kgm ²]				0,273	0,334	0,375	0,466	0,494	0,662
			[dBA]				97/82	98/83	99/84	99/84	100/85	100/85

Performance data based on the compression of air ($p_1= 1.0$ bar, $t_1= 20$ °C)

Discharge pressure p_2 [bar gauge]	Compressor size belt drive ratio	VM 15 R										
		B	B _{5/6}	B ₆	B _{6/7}	B ₇	B _{7/8}	B ₈	B _{8/9}	B ₉	B _{9/10}	
0,75	flow at inlet	\dot{V}_1 [m ³ /h]										
	compressor speed	nH [1/min]										
	motor speed	nM [1/min]										
	discharge temperature	t_2 [°C]										
	power at shaft / motor rating	$\dot{P}_{K/Mot}$ [kW]										
	power, idling $p_1 = p_2 = 1,0$ bar	\dot{P}_{Leer} [kW]										
	reduced moment of inertia	J [kgm ²]										
	Lp(A) w/o.h./w.h.	[dBA]										
1,00	flow at inlet	\dot{V}_1 [m ³ /h]										
	compressor speed	nH [1/min]										
	motor speed	nM [1/min]										
	discharge temperature	t_2 [°C]										
	power at shaft / motor rating	$\dot{P}_{K/Mot}$ [kW]										
	power, idling $p_1 = p_2 = 1,0$ bar	\dot{P}_{Leer} [kW]										
	reduced moment of inertia	J [kgm ²]										
	Lp(A) w/o.h./w.h.	[dBA]										
1,25	flow at inlet	\dot{V}_1 [m ³ /h]										
	compressor speed	nH [1/min]										
	motor speed	nM [1/min]										
	discharge temperature	t_2 [°C]										
	power at shaft / motor rating	$\dot{P}_{K/Mot}$ [kW]										
	power, idling $p_1 = p_2 = 1,0$ bar	\dot{P}_{Leer} [kW]										
	reduced moment of inertia	J [kgm ²]										
	Lp(A) w/o.h./w.h.	[dBA]										
1,50	flow at inlet	\dot{V}_1 [m ³ /h]										
	compressor speed	nH [1/min]										
	motor speed	nM [1/min]										
	discharge temperature	t_2 [°C]										
	power at shaft / motor rating	$\dot{P}_{K/Mot}$ [kW]										
	power, idling $p_1 = p_2 = 1,0$ bar	\dot{P}_{Leer} [kW]										
	reduced moment of inertia	J [kgm ²]										
	Lp(A) w/o.h./w.h.	[dBA]										
1,75	flow at inlet	\dot{V}_1 [m ³ /h]										
	compressor speed	nH [1/min]										
	motor speed	nM [1/min]										
	discharge temperature	t_2 [°C]										
	power at shaft / motor rating	$\dot{P}_{K/Mot}$ [kW]										
	power, idling $p_1 = p_2 = 1,0$ bar	\dot{P}_{Leer} [kW]										
	reduced moment of inertia	J [kgm ²]										
	Lp(A) w/o.h./w.h.	[dBA]										
2,00	flow at inlet	\dot{V}_1 [m ³ /h]	561	605	655	706	749	801	850	904	966	
	compressor speed	nH [1/min]	12851	13570	14391	15215	16134	17236	18276	19418	20698	
	motor speed	nM [1/min]	2950	2950	2950	2940	2940	2955	2955	2955	2970	
	discharge temperature	t_2 [°C]	163	161	160	159	160	162	163	165	168	
	power at shaft / motor rating	$\dot{P}_{K/Mot}$ [kW]	29,7 / 37	31,6 / 37	33,3 / 37	36,1 / 45	38,7 / 45	41,9 / 55	45,3 / 55	49,2 / 55	54 / 75	
	power, idling $p_1 = p_2 = 1,0$ bar	\dot{P}_{Leer} [kW]	12,6	13,9	15,4	17,2	19,1	21,5	23,9	26,8	29,9	
	reduced moment of inertia	J [kgm ²]	0,392	0,456	0,496	0,588	0,638	0,764	0,827	1,013	1,124	
	Lp(A) w/o.h./w.h.	[dBA]	94/78	94/79	95/80	96/81	96/82	97/83	98/83	98/84	99/85	
2,25	flow at inlet	\dot{V}_1 [m ³ /h]	553	597	644	698	745	793	842	901	958	
	compressor speed	nH [1/min]	12807	13570	14342	15215	16216	17236	18276	19516	20698	
	motor speed	nM [1/min]	2950	2950	2940	2940	2955	2955	2970	2970	2970	
	discharge temperature	t_2 [°C]	179	176	174	172	173	175	176	178	180	
	power at shaft / motor rating	$\dot{P}_{K/Mot}$ [kW]	32,5 / 37	34,4 / 37	36,6 / 45	39,2 / 45	42,2 / 55	45,3 / 55	48,9 / 55	54 / 75	58 / 75	
	power, idling $p_1 = p_2 = 1,0$ bar	\dot{P}_{Leer} [kW]	12,6	13,9	15,4	17,2	19,1	21,5	23,9	26,8	29,9	
	reduced moment of inertia	J [kgm ²]	0,392	0,456	0,496	0,588	0,668	0,764	0,827	1,044	1,124	
	Lp(A) w/o.h./w.h.	[dBA]	94/78	94/79	95/80	96/81	96/82	97/83	98/83	98/84	99/85	
2,50	flow at inlet	\dot{V}_1 [m ³ /h]	546	586	636	693	736	784	838	893	949	
	compressor speed	nH [1/min]	12807	13524	14342	15292	16216	17236	18369	19516	20698	
	motor speed	nM [1/min]	2940	2940	2940	2955	2955	2970	2970	2970	2970	
	discharge temperature	t_2 [°C]	194	192	189	186	187	188	190	191	193	
	power at shaft / motor rating	$\dot{P}_{K/Mot}$ [kW]	35,3 / 45	37,2 / 45	38,6 / 45	42,5 / 55	45,5 / 55	48,8 / 55	53 / 75	58 / 75	62 / 75	
	power, idling $p_1 = p_2 = 1,0$ bar	\dot{P}_{Leer} [kW]	18,4	13,9	15,4	17,2	19,1	21,5	23,9	26,8	29,9	
	reduced moment of inertia	J [kgm ²]	0,392	0,456	0,496	0,619	0,668	0,764	0,862	1,044	1,124	
	Lp(A) w/o.h./w.h.	[dBA]	94/79	95/79	95/80	96/81	96/82	97/83	98/84	99/84	100/85	
2,75	flow at inlet	\dot{V}_1 [m ³ /h]	540	583	638	691	734	780	830	884	941	
	compressor speed	nH [1/min]	12807	13524	14415	15292	16216	17323	18369	19516	20698	
	motor speed	nM [1/min]	2940	2940	2955	2955	2970	2970	2970	2970	2970	
	discharge temperature	t_2 [°C]	208	205	202	200	201	202	203	204	206	
	power at shaft / motor rating	$\dot{P}_{K/Mot}$ [kW]	37,6 / 45	39,9 / 45	42,9 / 55	45,9 / 55	49,2 / 55	53 / 75	57 / 75	62 / 75	66 / 75	
	power, idling $p_1 = p_2 = 1,0$ bar	\dot{P}_{Leer} [kW]	18,4	20,2	22,3	24,9	27,6	30,7	34,1	37,9	42,1	
	reduced moment of inertia	J [kgm ²]	0,392	0,456	0,515	0,619	0,668	0,8	0,862	1,044	1,198	
	Lp(A) w/o.h./w.h.	[dBA]	94/79	95/79	95/80	96/81	96/82	97/83	98/84	99/84	100/85	
3,00	flow at inlet	\dot{V}_1 [m ³ /h]	533	577	631	684	731	779	829	884	933	
	compressor speed	nH [1/min]	12807	13524	14415	15292	16299	17323	18369	19516	20698	
	motor speed	nM [1/min]	2940	2940	2955	2955	2970	2970	2970	2970	2970	
	discharge temperature	t_2 [°C]	222	218	215	212	213	214	216	218	219	
	power at shaft / motor rating	$\dot{P}_{K/Mot}$ [kW]	39,9 / 45	42,3 / 45	45,4 / 55	48,5 / 55	53 / 75	57 / 75	61 / 75	66 / 75	70 / 90	
	power, idling $p_1 = p_2 = 1,0$ bar	\dot{P}_{Leer} [kW]	18,4	20,2	22,3	24,9	27,6	30,7	34,1	37,9	42,1	
	reduced moment of inertia	J [kgm ²]	0,392	0,456	0,515	0,619	0,668	0,8	0,862	1,044	1,198	
	Lp(A) w/o.h./w.h.	[dBA]	94/79	95/79	95/80	96/81	96/82	97/84	98/84	99/84	100/85	
3,25	flow at inlet	\dot{V}_1 [m ³ /h]	526	574	624	681	724	772	822	877	933	
	compressor speed	nH [1/min]	12807	13593	14415	15370	16299	17323	18369	19516	20698	
	motor speed	nM [1/min]	2940	2955	2955	2970	2970	2970	2970	2970	2970	
	discharge temperature	t_2 [°C]	236	232	228	225	225	226	227	229	230	
	power at shaft / motor rating	$\dot{P}_{K/Mot}$ [kW]	42,2 / 45	45 / 55	48 / 55	52 / 75	55 / 75	60 / 75	64 / 75	69 / 90	74 / 90	
	power, idling $p_1 = p_2 = 1,0$ bar	\dot{P}_{Leer} [kW]	18,4	20,2	22,3	24,9	27,6	30,7	34,1	37,9	42,1	
	reduced moment of inertia	J [kgm ²]	0,392	0,456	0,515	0,619	0,668	0,8	0,862	1,123	1,198	
	Lp(A) w/o.h./w.h.	[dBA]	94/79	95/79	95/80	96/81	97/82	97/84	98/84	99/84	100/85	
3,50	flow at inlet	\dot{V}_1 [m ³ /h]			617	674	717	766	815	870	926	
	compressor speed	nH [1/min]			14415	15370	16299	17323	18369	19516	20698	
	motor speed	nM [1/min]			2955	2970	2970	2970	2970	2970	2970	
	discharge temperature	t_2 [°C]			241	238	238	238	239	240	241	
	power at shaft / motor rating	$\dot{P}_{K/Mot}$ [kW]			51 / 55	54 / 75	58 / 75	62 / 75	67 / 75	72 / 90	78 / 90	
	power, idling $p_1 = p_2 = 1,0$ bar	\dot{P}_{Leer} [kW]			22,3	24,9	27,6	30,7	34,1	37,9	42,1	
	reduced moment of inertia	J [kgm ²]			0,515	0,619	0,668	0,8	0,917	1,123	1,198	
	Lp(A) w/o.h./w.h.	[dBA]			95/80	96/81	96/83	98/83	98/84	99/85	100/86	

Performance data based on the compression of air ($p_1 = 1.0$ bar, $t_1 = 20$ °C)

Discharge pressure p_2 [bar gauge]	Compressor size belt drive ratio	VML 18 R											
		B	B ₂	B ₃	B ₄	B ₅	B ₆	B ₇	B ₈	B ₉	B _{9/10}		
0,75	flow at inlet	\dot{V}_1	[m ³ /h]	389	466	544	639	742	868	1008	1169	1252	
	compressor speed	nH	[1/min]	5001	5626	6251	7001	7813	8796	9895	11171	11833	
	motor speed	nM	[1/min]	2930	2930	2930	2930	2930	2945	2945	2950	2950	
	discharge temperature	t_2	[°C]	101	96	93	90	88	87	87	87	88	
	power at shaft / motor rating	$\dot{P}_{K/Mot}$	[kW]	11,9 / 15	12,5 / 15	13,9 / 18,5	15,7 / 18,5	17,7 / 22	20,4 / 30	23,5 / 30	27,9 / 37	30,4 / 37	
	power, idling $p_1 = p_2 = 1,0$ bar	P_{Leer}	[kW]	4,5	5,3	6,1	7,4	8,8	10,5	12,8	15,7	17,5	
	reduced moment of inertia	J	[kgm ²]	0,118	0,156	0,203	0,27	0,34	0,48	0,67	0,8	0,93	
	Lp(A) w/o.h./w.h.		[dBA]	89/69	90/71	91/71	92/72	92/73	92/74	93/75	94/76	94/76	
	1,00	flow at inlet	\dot{V}_1	[m ³ /h]	380	457	535	629	733	854	996	1150	1232
		compressor speed	nH	[1/min]	5001	5626	6251	7037	7853	8796	9912	11133	11793
motor speed		nM	[1/min]	2930	2930	2930	2945	2945	2945	2950	2940	2940	
discharge temperature		t_2	[°C]	125	119	115	112	108	106	104	103	104	
power at shaft / motor rating		$\dot{P}_{K/Mot}$	[kW]	13,9 / 18,5	15,8 / 18,5	17,8 / 22	20,2 / 30	22,6 / 30	25,6 / 30	29,3 / 37	33,9 / 45	36,6 / 45	
power, idling $p_1 = p_2 = 1,0$ bar		P_{Leer}	[kW]	6,6	7,9	9,3	7,4	8,8	10,5	12,8	15,7	17,5	
reduced moment of inertia		J	[kgm ²]	0,118	0,156	0,21	0,28	0,38	0,48	0,67	0,8	1,03	
Lp(A) w/o.h./w.h.			[dBA]	89/70	90/71	92/72	92/73	92/73	93/74	93/75	94/76	94/76	
1,25		flow at inlet	\dot{V}_1	[m ³ /h]	370	446	528	623	729	849	977	1136	1225
		compressor speed	nH	[1/min]	5001	5626	6283	7037	7867	8811	9878	11133	11853
	motor speed	nM	[1/min]	2930	2930	2945	2945	2950	2950	2940	2940	2955	
	discharge temperature	t_2	[°C]	149	140	134	130	126	124	122	120	120	
	power at shaft / motor rating	$\dot{P}_{K/Mot}$	[kW]	16,6 / 18,5	18,8 / 22	21,1 / 30	23,9 / 30	27,1 / 37	30,8 / 37	34,9 / 45	39,9 / 45	43,7 / 55	
	power, idling $p_1 = p_2 = 1,0$ bar	P_{Leer}	[kW]	6,6	7,9	9,3	11,0	13,1	15,7	12,8	15,7	17,5	
	reduced moment of inertia	J	[kgm ²]	0,123	0,164	0,21	0,28	0,38	0,48	0,72	0,87	1,13	
	Lp(A) w/o.h./w.h.		[dBA]	89/70	91/71	92/73	93/74	93/75	93/76	93/77	94/78	95/78	
	1,50	flow at inlet	\dot{V}_1	[m ³ /h]	359	439	517	614	718	834	981	1140	1219
		compressor speed	nH	[1/min]	5001	5654	6283	7049	7867	8781	9929	11190	11914
motor speed		nM	[1/min]	2930	2945	2945	2950	2950	2940	2955	2955	2970	
discharge temperature		t_2	[°C]	174	163	155	148	143	140	137	136	150	
power at shaft / motor rating		$\dot{P}_{K/Mot}$	[kW]	19,3 / 22	21,9 / 30	24,4 / 30	27,5 / 37	30,9 / 37	34,9 / 45	40,2 / 45	46,3 / 55	51 / 75	
power, idling $p_1 = p_2 = 1,0$ bar		P_{Leer}	[kW]	6,6	7,9	9,3	11,0	13,1	15,7	19,2	23,7	26,1	
reduced moment of inertia		J	[kgm ²]	0,123	0,164	0,21	0,28	0,38	0,52	0,72	0,88	1,2	
Lp(A) w/o.h./w.h.			[dBA]	90/72	91/73	92/74	93/75	94/76	96/77	96/78	98/78	98/78	
1,75		flow at inlet	\dot{V}_1	[m ³ /h]	351	428	508	603	703	823	969	1135	1218
		compressor speed	nH	[1/min]	5026	5654	6293	7049	7840	8781	9929	11246	11914
	motor speed	nM	[1/min]	2945	2945	2950	2950	2940	2940	2955	2970	2970	
	discharge temperature	t_2	[°C]	201	186	176	167	161	156	152	151	150	
	power at shaft / motor rating	$\dot{P}_{K/Mot}$	[kW]	22,2 / 30	24,9 / 30	27,7 / 37	31,1 / 37	34,7 / 45	39,2 / 45	44,9 / 55	52 / 75	56 / 75	
	power, idling $p_1 = p_2 = 1,0$ bar	P_{Leer}	[kW]	6,6	7,9	9,3	11,0	13,1	15,7	19,2	23,7	26,1	
	reduced moment of inertia	J	[kgm ²]	0,123	0,164	0,22	0,3	0,4	0,52	0,72	0,88	1,2	
	Lp(A) w/o.h./w.h.		[dBA]	90/72	92/73	92/74	94/75	96/76	97/78	97/78	99/79	99/79	
	2,00	flow at inlet	\dot{V}_1	[m ³ /h]			497	589	692	818	958	1124	1207
		compressor speed	nH	[1/min]			6293	7025	7840	8826	9929	11246	11914
motor speed		nM	[1/min]			2950	2940	2940	2955	2955	2970	2970	
discharge temperature		t_2	[°C]			198	188	180	173	168	165	164	
power at shaft / motor rating		$\dot{P}_{K/Mot}$	[kW]			31 / 37	34,5 / 45	38,6 / 45	43,7 / 55	49,6 / 55	57 / 75	61 / 75	
power, idling $p_1 = p_2 = 1,0$ bar		P_{Leer}	[kW]			9,3	11,0	13,1	15,7	19,2	23,7	26,1	
reduced moment of inertia		J	[kgm ²]			0,22	0,3	0,4	0,52	0,72	0,94	1,2	
Lp(A) w/o.h./w.h.			[dBA]			96/75	97/77	98/78	99/79	99/80	100/80	100/80	
2,25		flow at inlet	\dot{V}_1	[m ³ /h]									
		compressor speed	nH	[1/min]									
	motor speed	nM	[1/min]										
	discharge temperature	t_2	[°C]										
	power at shaft / motor rating	$\dot{P}_{K/Mot}$	[kW]										
	power, idling $p_1 = p_2 = 1,0$ bar	P_{Leer}	[kW]										
	reduced moment of inertia	J	[kgm ²]										
	Lp(A) w/o.h./w.h.		[dBA]										
	2,50	flow at inlet	\dot{V}_1	[m ³ /h]									
		compressor speed	nH	[1/min]									
motor speed		nM	[1/min]										
discharge temperature		t_2	[°C]										
power at shaft / motor rating		$\dot{P}_{K/Mot}$	[kW]										
power, idling $p_1 = p_2 = 1,0$ bar		P_{Leer}	[kW]										
reduced moment of inertia		J	[kgm ²]										
Lp(A) w/o.h./w.h.			[dBA]										
2,75		flow at inlet	\dot{V}_1	[m ³ /h]									
		compressor speed	nH	[1/min]									
	motor speed	nM	[1/min]										
	discharge temperature	t_2	[°C]										
	power at shaft / motor rating	$\dot{P}_{K/Mot}$	[kW]										
	power, idling $p_1 = p_2 = 1,0$ bar	P_{Leer}	[kW]										
	reduced moment of inertia	J	[kgm ²]										
	Lp(A) w/o.h./w.h.		[dBA]										
	3,00	flow at inlet	\dot{V}_1	[m ³ /h]									
		compressor speed	nH	[1/min]									
motor speed		nM	[1/min]										
discharge temperature		t_2	[°C]										
power at shaft / motor rating		$\dot{P}_{K/Mot}$	[kW]										
power, idling $p_1 = p_2 = 1,0$ bar		P_{Leer}	[kW]										
reduced moment of inertia		J	[kgm ²]										
Lp(A) w/o.h./w.h.			[dBA]										
3,25		flow at inlet	\dot{V}_1	[m ³ /h]									
		compressor speed	nH	[1/min]									
	motor speed	nM	[1/min]										
	discharge temperature	t_2	[°C]										
	power at shaft / motor rating	$\dot{P}_{K/Mot}$	[kW]										
	power, idling $p_1 = p_2 = 1,0$ bar	P_{Leer}	[kW]										
	reduced moment of inertia	J	[kgm ²]										
	Lp(A) w/o.h./w.h.		[dBA]										
	3,50	flow at inlet	\dot{V}_1	[m ³ /h]									
		compressor speed	nH	[1/min]									
motor speed		nM	[1/min]										
discharge temperature		t_2	[°C]										
power at shaft / motor rating		$\dot{P}_{K/Mot}$	[kW]										
power, idling $p_1 = p_2 = 1,0$ bar		P_{Leer}	[kW]										
reduced moment of inertia		J	[kgm ²]										
Lp(A) w/o.h./w.h.			[dBA]										

Performance data based on the compression of air (p₁= 1.0 bar, t₁ = 20 °C)

Discharge pressure p ₂ [bar gauge]	Compressor size		VM 21 R										
	belt drive ratio		B	B _{5/6}	B ₆	B _{6/7}	B ₇	B _{7/8}	B ₈	B _{8/9}	B ₉	B _{9/10}	
0,75	flow at inlet	V ₁	[m ³ /h]										
	compressor speed	nH	[1/min]										
	motor speed	nM	[1/min]										
	discharge temperature	t ₂	[°C]										
	power at shaft / motor rating	P _{K/Mot}	[kW]										
	power, idling p ₁ = p ₂ = 1,0 bar	P _{Leer}	[kW]										
	reduced moment of inertia Lp(A) w/o.h./w.h.	J	[kgm ²]										
			[dBA]										
1,00	flow at inlet	V ₁	[m ³ /h]										
	compressor speed	nH	[1/min]										
	motor speed	nM	[1/min]										
	discharge temperature	t ₂	[°C]										
	power at shaft / motor rating	P _{K/Mot}	[kW]										
	power, idling p ₁ = p ₂ = 1,0 bar	P _{Leer}	[kW]										
	reduced moment of inertia Lp(A) w/o.h./w.h.	J	[kgm ²]										
			[dBA]										
1,25	flow at inlet	V ₁	[m ³ /h]										
	compressor speed	nH	[1/min]										
	motor speed	nM	[1/min]										
	discharge temperature	t ₂	[°C]										
	power at shaft / motor rating	P _{K/Mot}	[kW]										
	power, idling p ₁ = p ₂ = 1,0 bar	P _{Leer}	[kW]										
	reduced moment of inertia Lp(A) w/o.h./w.h.	J	[kgm ²]										
			[dBA]										
1,50	flow at inlet	V ₁	[m ³ /h]										
	compressor speed	nH	[1/min]										
	motor speed	nM	[1/min]										
	discharge temperature	t ₂	[°C]										
	power at shaft / motor rating	P _{K/Mot}	[kW]										
	power, idling p ₁ = p ₂ = 1,0 bar	P _{Leer}	[kW]										
	reduced moment of inertia Lp(A) w/o.h./w.h.	J	[kgm ²]										
			[dBA]										
1,75	flow at inlet	V ₁	[m ³ /h]										
	compressor speed	nH	[1/min]										
	motor speed	nM	[1/min]										
	discharge temperature	t ₂	[°C]										
	power at shaft / motor rating	P _{K/Mot}	[kW]										
	power, idling p ₁ = p ₂ = 1,0 bar	P _{Leer}	[kW]										
	reduced moment of inertia Lp(A) w/o.h./w.h.	J	[kgm ²]										
			[dBA]										
2,00	flow at inlet	V ₁	[m ³ /h]		879	943	1016	1098	1160	1229	1300	1379	1461
	compressor speed	nH	[1/min]		12872	13593	14417	15370	16301	17321	18371	19517	20700
	motor speed	nM	[1/min]		2955	2955	2955	2970	2970	2970	2970	2970	2970
	discharge temperature	t ₂	[°C]		157	157	156	157	159	168	165	168	171
	power at shaft / motor rating	P _{K/Mot}	[kW]		44,4 / 55	47,4 / 55	52 / 55	56 / 75	61 / 75	67 / 75	72 / 75	79 / 90	86 / 90
	power, idling p ₁ = p ₂ = 1,0 bar	P _{Leer}	[kW]		27,3	29,7	32,9	36,3	40,3	44,8	50	56	63
	reduced moment of inertia Lp(A) w/o.h./w.h.	J	[kgm ²]		0,561	0,675	0,721	0,864	0,925	1,118	1,195	1,454	1,637
			[dBA]		95/73	95/73	96/74	96/76	98/78	99/83	101/84	101/84	102/85
2,25	flow at inlet	V ₁	[m ³ /h]		870	934	1014	1089	1151	1220	1291	1370	1454
	compressor speed	nH	[1/min]		12872	13593	14490	15370	16301	17321	18371	19517	20735
	motor speed	nM	[1/min]		2955	2955	2970	2970	2970	2970	2970	2970	2975
	discharge temperature	t ₂	[°C]		169	168	167	167	170	172	175	178	181
	power at shaft / motor rating	P _{K/Mot}	[kW]		47,7 / 55	51 / 55	56 / 75	60 / 75	65 / 75	71 / 75	77 / 90	84 / 90	92 / 110
	power, idling p ₁ = p ₂ = 1,0 bar	P _{Leer}	[kW]		27,3	29,7	32,9	36,3	40,3	44,8	50	56	63
	reduced moment of inertia Lp(A) w/o.h./w.h.	J	[kgm ²]		0,561	0,675	0,722	0,864	0,925	1,118	1,195	1,454	1,636
			[dBA]		96/73	96/73	98/74	99/77	100/78	100/84	100/84	102/85	102/85
2,50	flow at inlet	V ₁	[m ³ /h]		861	931	1005	1080	1142	1211	1282	1363	1445
	compressor speed	nH	[1/min]		12872	13662	14490	15370	16301	17321	18371	19550	20735
	motor speed	nM	[1/min]		2955	2970	2970	2970	2970	2970	2970	2975	2975
	discharge temperature	t ₂	[°C]		181	180	178	178	180	183	185	188	191
	power at shaft / motor rating	P _{K/Mot}	[kW]		52 / 55	55 / 75	59 / 75	64 / 75	69 / 75	75 / 90	81 / 90	89 / 110	97 / 110
	power, idling p ₁ = p ₂ = 1,0 bar	P _{Leer}	[kW]		27,3	29,7	32,9	36,3	40,3	44,8	50	56	63
	reduced moment of inertia Lp(A) w/o.h./w.h.	J	[kgm ²]		0,561	0,675	0,722	0,864	0,925	1,119	1,257	1,539	1,637
			[dBA]		96/74	97/74	98/75	99/77	100/78	101/84	101/84	102/85	102/85
2,75	flow at inlet	V ₁	[m ³ /h]		858	922	996	1071	1133	1202	1273	1354	1436
	compressor speed	nH	[1/min]		12938	13662	14490	15370	16301	17321	18371	19550	20735
	motor speed	nM	[1/min]		2970	2970	2970	2970	2970	2970	2970	2975	2975
	discharge temperature	t ₂	[°C]		193	192	190	189	191	194	196	199	202
	power at shaft / motor rating	P _{K/Mot}	[kW]		55 / 75	59 / 75	63 / 75	68 / 75	73 / 75	80 / 90	86 / 90	94 / 110	102 / 110
	power, idling p ₁ = p ₂ = 1,0 bar	P _{Leer}	[kW]		27,3	29,7	32,9	36,3	40,3	44,8	50	56	63
	reduced moment of inertia Lp(A) w/o.h./w.h.	J	[kgm ²]		0,561	0,675	0,722	0,864	0,925	1,119	1,257	1,539	1,637
			[dBA]		96/74	97/74	98/75	99/77	101/78	101/84	101/85	102/85	102/85
3,00	flow at inlet	V ₁	[m ³ /h]		857	921	995	1070	1124	1193	1267	1345	1427
	compressor speed	nH	[1/min]		12938	13662	14490	15370	16301	17321	18402	19550	20735
	motor speed	nM	[1/min]		2970	2970	2970	2970	2970	2970	2975	2975	2975
	discharge temperature	t ₂	[°C]		204	203	201	201	203	205	207	210	212
	power at shaft / motor rating	P _{K/Mot}	[kW]		59 / 75	62 / 75	67 / 75	73 / 75	78 / 90	84 / 90	91 / 110	99 / 110	107 / 110
	power, idling p ₁ = p ₂ = 1,0 bar	P _{Leer}	[kW]		41,1	44,6	49	54,6	40,3	44,8	50	56	63
	reduced moment of inertia Lp(A) w/o.h./w.h.	J	[kgm ²]		0,561	0,675	0,722	0,865	0,925	1,119	1,257	1,539	1,637
			[dBA]		96/74	97/75	98/75	99/77	101/78	101/84	101/85	102/85	102/85
3,25	flow at inlet	V ₁	[m ³ /h]		849	913	987	1062	1125	1194	1267	1346	1428
	compressor speed	nH	[1/min]		12938	13662	14490	15370	16301	17321	18402	19550	20735
	motor speed	nM	[1/min]		2970	2970	2970	2970	2970	2970	2975	2975	2975
	discharge temperature	t ₂	[°C]		214	212	210	209	212	214	217	219	222
	power at shaft / motor rating	P _{K/Mot}	[kW]		61 / 75	65 / 75	70 / 75	76 / 90	81 / 90	88 / 90	96 / 110	104 / 110	112 / 132
	power, idling p ₁ = p ₂ = 1,0 bar	P _{Leer}	[kW]		41,1	44,6	49	54,6	59,6	65,5	72,9	79,6	87,7
	reduced moment of inertia Lp(A) w/o.h./w.h.	J	[kgm ²]		0,561	0,675	0,722	0,865	0,963	1,119	1,257	1,54	1,637
			[dBA]		98/75	98/75	99/76	100/77	101/79	102/85	102/85	102/85	102/85
3,50	flow at inlet	V ₁	[m ³ /h]		842	906	980	1055	1117	1188	1260	1338	1420
	compressor speed	nH	[1/min]		12938	13662	14490	15370	16301	17351	18402	19550	20735
	motor speed	nM	[1/min]		2970	2970	2970	2970	2970	2975	2975	2975	2975
	discharge temperature	t ₂	[°C]		224	222	220	218	220	223	225	227	230
	power at shaft / motor rating	P _{K/Mot}	[kW]		64 / 75	68 / 75	73 / 75	79 / 90	85 / 90	96 / 110	99 / 110	107 / 110	116 / 132
	power, idling p ₁ = p ₂ = 1,0 bar	P _{Leer}	[kW]		41,1	44,6	49	54,6	59,6	65,5	72,9	79,6	87,7
	reduced moment of inertia Lp(A) w/o.h./w.h.	J	[kgm ²]		0,561	0,675	0,722	0,865	0,963	1,18	1,257	1,54	1,637
			[dBA]		98/75	99/75	99/76	100/77	101/79	102/85	102/86	102/86	102/86

Performance data based on the compression of air ($p_1 = 1.0 \text{ bar}$, $t_1 = 20 \text{ °C}$)

Discharge pressure p_2 [bar gauge]	Compressor size belt drive ratio	VML 25 R									
		B	B ₄	B _{4/5}	B ₅	B _{5/6}	B ₆	B _{6/7}	B ₇	B _{7/8}	
0,75	flow at inlet	\dot{V}_1 [m ³ /h]	1091	1171	1247	1336	1425	1520	1629	1754	
	compressor speed	nH [1/min]	10566	11207	11815	12529	13230	13983	14834	15811	
	motor speed	nM [1/min]	2945	2945	2950	2950	2950	2940	2940	2955	
	discharge temperature	t_2 [°C]	89	89	90	90	91	92	94	96	
	power at shaft / motor rating	$\dot{P}_{K/Mot}$ [kW]	26,2 / 30	28,3 / 37	30,3 / 37	32,9 / 37	35,5 / 45	38,5 / 45	42,1 / 45	46,5 / 55	
	power, idling $p_1 = p_2 = 1,0 \text{ bar}$	\dot{P}_{Leer} [kW]	14,6	16,3	17,8	20,0	22,2	24,8	28,0	31,3	
	reduced moment of inertia	J [kgm ²]	0,481	0,527	0,602	0,686	0,806	0,876	1,03	1,115	
	Lp(A) w/o.h./w.h.	[dBA]	93/76	93/76	93/77	94/77	94/77	94/78	95/78	95/79	
	flow at inlet	\dot{V}_1 [m ³ /h]	1079	1159	1227	1317	1405	1515	1624	1750	
	compressor speed	nH [1/min]	10584	11226	11775	12487	13185	14055	14909	15891	
motor speed	nM [1/min]	2950	2950	2940	2940	2940	2955	2955	2970		
discharge temperature	t_2 [°C]	106	106	106	106	107	108	109	110		
power at shaft / motor rating	$\dot{P}_{K/Mot}$ [kW]	32,4 / 37	34,8 / 45	36,9 / 45	39,7 / 45	42,6 / 45	46,5 / 55	51 / 55	56 / 75		
power, idling $p_1 = p_2 = 1,0 \text{ bar}$	\dot{P}_{Leer} [kW]	14,6	16,3	17,8	20,0	22,2	24,8	28,0	31,3		
reduced moment of inertia	J [kgm ²]	0,483	0,528	0,602	0,686	0,806	0,876	1,033	1,115		
Lp(A) w/o.h./w.h.	[dBA]	94/76	94/77	94/77	95/77	95/78	95/78	96/78	96/79		
flow at inlet	\dot{V}_1 [m ³ /h]	1060	1162	1213	1310	1399	1510	1619	1735		
compressor speed	nH [1/min]	10548	11268	11775	12550	13253	14126	14985	15891		
motor speed	nM [1/min]	2940	2965	2940	2955	2955	2970	2970	2970		
discharge temperature	t_2 [°C]	124	122	123	123	123	123	124	125		
power at shaft / motor rating	$\dot{P}_{K/Mot}$ [kW]	38,4 / 45	41,1 / 45	43,6 / 45	47,1 / 55	51 / 55	55 / 75	59 / 75	64 / 75		
power, idling $p_1 = p_2 = 1,0 \text{ bar}$	\dot{P}_{Leer} [kW]	14,6	16,3	17,8	20,0	22,2	24,8	28,0	31,3		
reduced moment of inertia	J [kgm ²]	0,483	0,528	0,602	0,688	0,809	0,876	1,03	1,115		
Lp(A) w/o.h./w.h.	[dBA]	94/77	95/78	95/78	95/78	96/79	96/79	97/79	97/79		
flow at inlet	\dot{V}_1 [m ³ /h]	1063	1143	1217	1304	1393	1496	1605	1721		
compressor speed	nH [1/min]	10602	11245	11835	12614	13320	14126	14985	15891		
motor speed	nM [1/min]	2955	2955	2955	2970	2970	2970	2970	2970		
discharge temperature	t_2 [°C]	140	140	140	140	140	140	140	141		
power at shaft / motor rating	$\dot{P}_{K/Mot}$ [kW]	44,5 / 55	47,8 / 55	51 / 55	55 / 75	59 / 75	63 / 75	68 / 75	73 / 75		
power, idling $p_1 = p_2 = 1,0 \text{ bar}$	\dot{P}_{Leer} [kW]	22,0	24,3	26,6	29,4	32,2	36,0	40,1	44,6		
reduced moment of inertia	J [kgm ²]	0,483	0,53	0,604	0,688	0,809	0,876	1,03	1,118		
Lp(A) w/o.h./w.h.	[dBA]	96/78	96/79	97/79	97/79	97/79	97/80	98/80	98/80		
flow at inlet	\dot{V}_1 [m ³ /h]	1052	1132	1214	1304	1393	1495	1605	1721		
compressor speed	nH [1/min]	10602	11245	11895	12614	13320	14126	14985	15891		
motor speed	nM [1/min]	2955	2955	2970	2970	2970	2970	2970	2970		
discharge temperature	t_2 [°C]	155	154	154	154	154	154	155	156		
power at shaft / motor rating	$\dot{P}_{K/Mot}$ [kW]	49,6 / 55	54 / 55	57 / 75	61 / 75	66 / 75	71 / 75	76 / 90	82 / 90		
power, idling $p_1 = p_2 = 1,0 \text{ bar}$	\dot{P}_{Leer} [kW]	22,0	24,3	26,6	29,4	32,4	36,0	40,1	44,6		
reduced moment of inertia	J [kgm ²]	0,483	0,53	0,604	0,688	0,809	0,876	1,033	1,118		
Lp(A) w/o.h./w.h.	[dBA]	97/78	97/79	98/79	98/79	98/80	98/80	99/81	99/81		
flow at inlet	\dot{V}_1 [m ³ /h]	1048	1128	1202	1293	1382	1484	1594	1713		
compressor speed	nH [1/min]	10656	11302	11895	12614	13320	14126	14985	15918		
motor speed	nM [1/min]	2970	2970	2970	2970	2970	2970	2970	2975		
discharge temperature	t_2 [°C]	170	169	168	168	167	168	168	169		
power at shaft / motor rating	$\dot{P}_{K/Mot}$ [kW]	55 / 75	59 / 75	63 / 75	67 / 75	72 / 75	77 / 90	83 / 90	90 / 110		
power, idling $p_1 = p_2 = 1,0 \text{ bar}$	\dot{P}_{Leer} [kW]	22,0	24,3	26,6	29,4	32,4	36,0	40,1	44,6		
reduced moment of inertia	J [kgm ²]	0,483	0,53	0,604	0,688	0,809	0,876	1,033	1,164		
Lp(A) w/o.h./w.h.	[dBA]	99/80	99/81	100/81	100/81	100/81	100/81	100/82	101/82		
flow at inlet	\dot{V}_1 [m ³ /h]										
compressor speed	nH [1/min]										
motor speed	nM [1/min]										
discharge temperature	t_2 [°C]										
power at shaft / motor rating	$\dot{P}_{K/Mot}$ [kW]										
power, idling $p_1 = p_2 = 1,0 \text{ bar}$	\dot{P}_{Leer} [kW]										
reduced moment of inertia	J [kgm ²]										
Lp(A) w/o.h./w.h.	[dBA]										
flow at inlet	\dot{V}_1 [m ³ /h]										
compressor speed	nH [1/min]										
motor speed	nM [1/min]										
discharge temperature	t_2 [°C]										
power at shaft / motor rating	$\dot{P}_{K/Mot}$ [kW]										
power, idling $p_1 = p_2 = 1,0 \text{ bar}$	\dot{P}_{Leer} [kW]										
reduced moment of inertia	J [kgm ²]										
Lp(A) w/o.h./w.h.	[dBA]										
flow at inlet	\dot{V}_1 [m ³ /h]										
compressor speed	nH [1/min]										
motor speed	nM [1/min]										
discharge temperature	t_2 [°C]										
power at shaft / motor rating	$\dot{P}_{K/Mot}$ [kW]										
power, idling $p_1 = p_2 = 1,0 \text{ bar}$	\dot{P}_{Leer} [kW]										
reduced moment of inertia	J [kgm ²]										
Lp(A) w/o.h./w.h.	[dBA]										
flow at inlet	\dot{V}_1 [m ³ /h]										
compressor speed	nH [1/min]										
motor speed	nM [1/min]										
discharge temperature	t_2 [°C]										
power at shaft / motor rating	$\dot{P}_{K/Mot}$ [kW]										
power, idling $p_1 = p_2 = 1,0 \text{ bar}$	\dot{P}_{Leer} [kW]										
reduced moment of inertia	J [kgm ²]										
Lp(A) w/o.h./w.h.	[dBA]										

Performance data based on the compression of air ($p_1= 1.0 \text{ bar}$, $t_1= 20 \text{ °C}$)

Discharge pressure p_2 [bar gauge]	Compressor size belt drive ratio	VM 37 R										
		B	B_4	$B_{4,5}$	B_5	$B_{5,6}$	B_6	$B_{6,7}$	B_7	$B_{7,8}$	B_8	
0,75	flow at inlet	\dot{V}_1 [m³/h]										
	compressor speed	nH [1/min]										
	motor speed	nM [1/min]										
	discharge temperature	t_2 [°C]										
	power at shaft / motor rating	$\dot{P}_{K/Mot}$ [kW]										
	power, idling $p_1= p_2= 1,0 \text{ bar}$	\dot{P}_{Leer} [kW]										
	reduced moment of inertia	J [kgm²]										
	Lp(A) w/o.h./w.h.	[dBA]										
1,00	flow at inlet	\dot{V}_1 [m³/h]										
	compressor speed	nH [1/min]										
	motor speed	nM [1/min]										
	discharge temperature	t_2 [°C]										
	power at shaft / motor rating	$\dot{P}_{K/Mot}$ [kW]										
	power, idling $p_1= p_2= 1,0 \text{ bar}$	\dot{P}_{Leer} [kW]										
	reduced moment of inertia	J [kgm²]										
	Lp(A) w/o.h./w.h.	[dBA]										
1,25	flow at inlet	\dot{V}_1 [m³/h]										
	compressor speed	nH [1/min]										
	motor speed	nM [1/min]										
	discharge temperature	t_2 [°C]										
	power at shaft / motor rating	$\dot{P}_{K/Mot}$ [kW]										
	power, idling $p_1= p_2= 1,0 \text{ bar}$	\dot{P}_{Leer} [kW]										
	reduced moment of inertia	J [kgm²]										
	Lp(A) w/o.h./w.h.	[dBA]										
1,50	flow at inlet	\dot{V}_1 [m³/h]										
	compressor speed	nH [1/min]										
	motor speed	nM [1/min]										
	discharge temperature	t_2 [°C]										
	power at shaft / motor rating	$\dot{P}_{K/Mot}$ [kW]										
	power, idling $p_1= p_2= 1,0 \text{ bar}$	\dot{P}_{Leer} [kW]										
	reduced moment of inertia	J [kgm²]										
	Lp(A) w/o.h./w.h.	[dBA]										
1,75	flow at inlet	\dot{V}_1 [m³/h]										
	compressor speed	nH [1/min]										
	motor speed	nM [1/min]										
	discharge temperature	t_2 [°C]										
	power at shaft / motor rating	$\dot{P}_{K/Mot}$ [kW]										
	power, idling $p_1= p_2= 1,0 \text{ bar}$	\dot{P}_{Leer} [kW]										
	reduced moment of inertia	J [kgm²]										
	Lp(A) w/o.h./w.h.	[dBA]										
2,00	flow at inlet	\dot{V}_1 [m³/h]	1390	1505	1609	1733	1828	1952	2061	2198	2323	
	compressor speed	nH [1/min]	10478	11168	11788	12607	13307	14205	14994	15980	16868	
	motor speed	nM [1/min]	2970	2970	2970	2975	2975	2975	2975	2975	2975	
	discharge temperature	t_2 [°C]	154	154	154	155	157	160	162	165	168	
	power at shaft / motor rating	$\dot{P}_{K/Mot}$ [kW]	70 / 75	76 / 90	82 / 90	90 / 110	97 / 110	107 / 110	116 / 132	129 / 132	141 / 160	
	power, idling $p_1= p_2= 1,0 \text{ bar}$	\dot{P}_{Leer} [kW]	39,6	45,1	50,3	57,3	63,7	73,1	81,4	92	101,5	
	reduced moment of inertia	J [kgm²]	0,946	1,095	1,212	1,403	1,612	1,882	2,486	2,848	3,017	
	Lp(A) w/o.h./w.h.	[dBA]	94/77	94/78	95/79	96/79	97/80	98/80	99/80	99/81	99/81	
2,25	flow at inlet	\dot{V}_1 [m³/h]	1378	1493	1597	1721	1817	1940	2049	2186	2311	
	compressor speed	nH [1/min]	10478	11168	11788	12607	13307	14205	14994	15980	16868	
	motor speed	nM [1/min]	2970	2970	2970	2975	2975	2975	2975	2975	2975	
	discharge temperature	t_2 [°C]	166	165	165	166	167	170	172	175	177	
	power at shaft / motor rating	$\dot{P}_{K/Mot}$ [kW]	75 / 90	81 / 90	87 / 90	95 / 110	103 / 110	113 / 132	122 / 132	135 / 160	147 / 160	
	power, idling $p_1= p_2= 1,0 \text{ bar}$	\dot{P}_{Leer} [kW]	39,6	45,1	50,3	57,3	63,7	73,1	81,4	92	101,5	
	reduced moment of inertia	J [kgm²]	0,946	1,095	1,212	1,457	1,612	2,353	2,486	2,848	3,162	
	Lp(A) w/o.h./w.h.	[dBA]	95/77	95/78	96/79	97/79	98/80	98/80	99/80	99/81	100/81	
2,50	flow at inlet	\dot{V}_1 [m³/h]	1366	1481	1588	1709	1805	1928	2037	2174	2299	
	compressor speed	nH [1/min]	10478	11168	11808	12607	13307	14205	14994	15980	16868	
	motor speed	nM [1/min]	2970	2970	2975	2975	2975	2975	2975	2975	2975	
	discharge temperature	t_2 [°C]	177	176	175	176	178	180	182	185	187	
	power at shaft / motor rating	$\dot{P}_{K/Mot}$ [kW]	80 / 90	86 / 90	93 / 110	101 / 110	109 / 132	119 / 132	129 / 132	142 / 160	154 / 160	
	power, idling $p_1= p_2= 1,0 \text{ bar}$	\dot{P}_{Leer} [kW]	39,6	45,1	50,3	57,3	63,7	73,1	81,4	92	101,5	
	reduced moment of inertia	J [kgm²]	0,946	1,095	1,258	1,457	1,747	2,353	2,487	2,848	3,162	
	Lp(A) w/o.h./w.h.	[dBA]	96/77	96/79	97/79	98/79	99/80	99/80	100/80	100/81	101/81	
2,75	flow at inlet	\dot{V}_1 [m³/h]	1355	1473	1577	1697	1793	1916	2025	2163	2287	
	compressor speed	nH [1/min]	10478	11168	11808	12607	13307	14205	14994	15980	16868	
	motor speed	nM [1/min]	2970	2975	2975	2975	2975	2975	2975	2975	2975	
	discharge temperature	t_2 [°C]	189	187	186	187	188	190	192	195	197	
	power at shaft / motor rating	$\dot{P}_{K/Mot}$ [kW]	85 / 90	92 / 110	98 / 110	107 / 110	115 / 132	126 / 132	135 / 160	149 / 160	161 / 200	
	power, idling $p_1= p_2= 1,0 \text{ bar}$	\dot{P}_{Leer} [kW]	39,6	45,1	50,3	57,3	63,7	73,1	81,4	92	101,5	
	reduced moment of inertia	J [kgm²]	0,946	1,132	1,258	1,457	1,747	2,353	2,487	2,993	3,163	
	Lp(A) w/o.h./w.h.	[dBA]	98/77	99/79	99/80	100/80	100/80	101/81	101/81	101/82	101/82	
3,00	flow at inlet	\dot{V}_1 [m³/h]	1356	1471	1565	1685	1781	1904	2013	2151	2275	
	compressor speed	nH [1/min]	10496	11186	11808	12607	13307	14205	14994	15980	16868	
	motor speed	nM [1/min]	2975	2975	2975	2975	2975	2975	2975	2975	2975	
	discharge temperature	t_2 [°C]	200	198	198	198	199	201	202	205	207	
	power at shaft / motor rating	$\dot{P}_{K/Mot}$ [kW]	91 / 110	98 / 110	104 / 110	113 / 132	121 / 132	132 / 160	142 / 160	156 / 160	168 / 200	
	power, idling $p_1= p_2= 1,0 \text{ bar}$	\dot{P}_{Leer} [kW]	60,9	67,6	75,3	85,5	94,5	106,9	117,6	129,8	140,7	
	reduced moment of inertia	J [kgm²]	0,986	1,132	1,258	1,642	1,747	2,354	2,412	2,993	3,163	
	Lp(A) w/o.h./w.h.	[dBA]	100/78	100/79	100/80	100/80	100/80	101/81	101/81	101/82	102/83	
3,25	flow at inlet	\dot{V}_1 [m³/h]	1346	1461	1565	1686	1782	1905	2014	2151	2276	
	compressor speed	nH [1/min]	10496	11186	11808	12607	13307	14205	14994	15980	16868	
	motor speed	nM [1/min]	2975	2975	2975	2975	2975	2975	2975	2975	2975	
	discharge temperature	t_2 [°C]	209	207	206	207	208	210	212	214	217	
	power at shaft / motor rating	$\dot{P}_{K/Mot}$ [kW]	94 / 110	102 / 110	109 / 132	119 / 132	127 / 132	139 / 160	149 / 160	163 / 200	176 / 200	
	power, idling $p_1= p_2= 1,0 \text{ bar}$	\dot{P}_{Leer} [kW]	60,9	67,6	75,3	85,5	94,5	106,9	117,6	129,8	140,7	
	reduced moment of inertia	J [kgm²]	0,986	1,132	1,388	1,642	1,748	2,354	2,412	2,993	3,163	
	Lp(A) w/o.h./w.h.	[dBA]	100/78	100/79	100/80	100/80	100/80	101/81	101/82	102/82	102/83	
3,50	flow at inlet	\dot{V}_1 [m³/h]	1336	1451	1555	1676	1772	1895	2004	2141	2266	
	compressor speed	nH [1/min]	10496	11113	11808	12607	13307	14205	14994	15980	16868	
	motor speed	nM [1/min]	2975	2975	2975	2975	2975	2975	2975	2975	2975	
	discharge temperature	t_2 [°C]	218	216	215	215	216	218	220	222	224	
	power at shaft / motor rating	$\dot{P}_{K/Mot}$ [kW]	98 / 110	106 / 110	113 / 132	123 / 132	132 / 160	144 / 160	154 / 160	168 / 200	182 / 200	
	power, idling $p_1= p_2= 1,0 \text{ bar}$	\dot{P}_{Leer} [kW]	60,9	67,6	75,3	85,5	94,5	106,9	117,6	129,8	140,7	
	reduced moment of inertia	J [kgm²]	0,986	1,132	1,388	1,642	1,748	2,354	2,412	2,994	3,163	
	Lp(A) w/o.h./w.h.	[dBA]	100/79	100/79	100/80	100/80	100/80	101/81	101/82	102/82	102/83	

Performance data based on the compression of air ($p_1 = 1.0 \text{ bar}$, $t_1 = 20 \text{ }^\circ\text{C}$)

Discharge pressure p_2 [bar gauge]	Compressor size belt drive ratio	VML 40 R										
		B	B ₂	B ₃	B ₄	B ₅	B ₆	B ₇	B ₈	B ₉	B ₁₀	
0,75	flow at inlet	\dot{V}_1 [m ³ /h]	891	1011	1167	1340	1531	1762	2011	2318	2592	
	compressor speed	nH [1/min]	5050	5611	6283	7025	7840	8820	9992	11314	12727	
	motor speed	nM [1/min]	2945	2945	2945	2950	2940	2940	2955	2970	2970	
	discharge temperature	t_2 [°C]	90	88	87	87	87	87	89	93	98	
	power at shaft / motor rating	$\dot{P}_{K/Mot}$ [kW]	21,8 / 30	24,5 / 30	27,9 / 30	31,9 / 37	36,7 / 45	43 / 45	52 / 55	63 / 75	77 / 90	
	power, idling $p_1 = p_2 = 1,0 \text{ bar}$	P_{Leer} [kW]	9,4	11	13,2	15,8	19,5	24,2	30,7	39,9	53	
	reduced moment of inertia	J [kgm ²]	0,258	0,32	0,4	0,51	0,64	0,82	1,09	1,46	2,04	
	Lp(A) w/o.h./w.h.	[dBA]	91/73	92/73	94/75	96/77	97/78	98/80	99/82	100/82	100/82	
	1,00	flow at inlet	\dot{V}_1 [m ³ /h]	868	993	1149	1324	1520	1753	2033	2298	2575
		compressor speed	nH [1/min]	5050	5621	6293	7001	7880	8865	10043	11314	12749
motor speed		nM [1/min]	2945	2950	2950	2940	2955	2955	2970	2970	2975	
discharge temperature		t_2 [°C]	111	109	106	105	104	104	104	107	113	
power at shaft / motor rating		$\dot{P}_{K/Mot}$ [kW]	27,9 / 30	31,2 / 37	35,2 / 37	39,7 / 45	45,6 / 55	53 / 55	63 / 75	74 / 90	89 / 110	
power, idling $p_1 = p_2 = 1,0 \text{ bar}$		P_{Leer} [kW]	13,7	11	13,2	15,8	19,5	24,2	30,7	39,9	53	
reduced moment of inertia		J [kgm ²]	0,258	0,32	0,4	0,52	0,66	0,84	1,12	1,53	2,38	
Lp(A) w/o.h./w.h.		[dBA]	93/73	93/73	96/75	98/77	99/79	100/80	101/81	101/82	101/82	
1,25		flow at inlet	\dot{V}_1 [m ³ /h]	854	979	1135	1313	1509	1743	2013	2277	2555
		compressor speed	nH [1/min]	5058	5602	6272	7037	7920	8910	10043	11314	12749
	motor speed	nM [1/min]	2950	2940	2940	2955	2970	2970	2970	2970	2975	
	discharge temperature	t_2 [°C]	129	127	124	123	122	120	120	123	128	
	power at shaft / motor rating	$\dot{P}_{K/Mot}$ [kW]	32,9 / 37	36,8 / 45	41,9 / 45	48 / 55	55 / 75	63 / 75	73 / 75	86 / 90	102 / 110	
	power, idling $p_1 = p_2 = 1,0 \text{ bar}$	P_{Leer} [kW]	13,7	16,3	19,5	23,6	28,7	35,7	45,1	58,2	75	
	reduced moment of inertia	J [kgm ²]	0,258	0,33	0,42	0,52	0,68	0,87	1,18	1,53	2,38	
	Lp(A) w/o.h./w.h.	[dBA]	95/74	95/74	97/76	99/78	100/79	100/80	102/81	102/82	103/83	
	1,50	flow at inlet	\dot{V}_1 [m ³ /h]	834	963	1126	1305	1504	1738	1993	2261	2535
		compressor speed	nH [1/min]	5041	5602	6304	7073	7920	8910	10043	11333	12749
motor speed		nM [1/min]	2940	2940	2955	2970	2970	2970	2970	2975	2975	
discharge temperature		t_2 [°C]	149	144	141	138	137	136	137	139	143	
power at shaft / motor rating		$\dot{P}_{K/Mot}$ [kW]	37,8 / 45	42,2 / 45	48,1 / 55	55 / 75	63 / 75	73 / 75	84 / 90	98 / 110	111 / 132	
power, idling $p_1 = p_2 = 1,0 \text{ bar}$		P_{Leer} [kW]	13,7	16,3	19,5	23,6	28,7	35,7	45,1	58,2	75	
reduced moment of inertia		J [kgm ²]	0,265	0,33	0,42	0,53	0,68	0,92	1,18	1,99	2,54	
Lp(A) w/o.h./w.h.		[dBA]	95/74	96/74	98/76	100/78	101/79	101/80	102/81	103/82	105/83	
1,75		flow at inlet	\dot{V}_1 [m ³ /h]	818	954	1118	1289	1488	1722	1996	2260	2515
		compressor speed	nH [1/min]	5041	5630	6336	7073	7920	8910	10059	11333	12749
	motor speed	nM [1/min]	2940	2955	2970	2970	2970	2970	2975	2975	2975	
	discharge temperature	t_2 [°C]	170	163	159	155	153	151	151	154	160	
	power at shaft / motor rating	$\dot{P}_{K/Mot}$ [kW]	43 / 45	48,2 / 55	55 / 75	62 / 75	71 / 75	81 / 90	94 / 110	110 / 132	129 / 132	
	power, idling $p_1 = p_2 = 1,0 \text{ bar}$	P_{Leer} [kW]	13,7	16,3	19,5	23,6	28,7	35,7	45,1	58,2	75	
	reduced moment of inertia	J [kgm ²]	0,265	0,34	0,42	0,53	0,68	0,92	1,35	1,99	2,54	
	Lp(A) w/o.h./w.h.	[dBA]	95/75	96/75	99/77	101/79	101/80	101/80	102/81	103/82	105/83	
	2,00	flow at inlet	\dot{V}_1 [m ³ /h]	808	945	1102	1273	1472	1710	1980	2244	
		compressor speed	nH [1/min]	5067	5659	6336	7073	7920	8925	10059	11333	
motor speed		nM [1/min]	2955	2970	2970	2970	2970	2975	2975	2975		
discharge temperature		t_2 [°C]	191	183	177	173	169	167	166	169		
power at shaft / motor rating		$\dot{P}_{K/Mot}$ [kW]	48,6 / 55	55 / 75	62 / 75	69 / 75	78 / 90	90 / 110	104 / 110	120 / 132		
power, idling $p_1 = p_2 = 1,0 \text{ bar}$		P_{Leer} [kW]	13,7	16,3	19,5	23,6	28,7	35,7	45,1	58,2		
reduced moment of inertia		J [kgm ²]	0,283	0,34	0,42	0,53	0,71	1,08	1,35	1,92		
Lp(A) w/o.h./w.h.		[dBA]	96/75	97/75	99/78	101/80	102/81	102/81	103/81	104/82		
2,25		flow at inlet	\dot{V}_1 [m ³ /h]									
		compressor speed	nH [1/min]									
	motor speed	nM [1/min]										
	discharge temperature	t_2 [°C]										
	power at shaft / motor rating	$\dot{P}_{K/Mot}$ [kW]										
	power, idling $p_1 = p_2 = 1,0 \text{ bar}$	P_{Leer} [kW]										
	reduced moment of inertia	J [kgm ²]										
	Lp(A) w/o.h./w.h.	[dBA]										
	2,50	flow at inlet	\dot{V}_1 [m ³ /h]									
		compressor speed	nH [1/min]									
motor speed		nM [1/min]										
discharge temperature		t_2 [°C]										
power at shaft / motor rating		$\dot{P}_{K/Mot}$ [kW]										
power, idling $p_1 = p_2 = 1,0 \text{ bar}$		P_{Leer} [kW]										
reduced moment of inertia		J [kgm ²]										
Lp(A) w/o.h./w.h.		[dBA]										
2,75		flow at inlet	\dot{V}_1 [m ³ /h]									
		compressor speed	nH [1/min]									
	motor speed	nM [1/min]										
	discharge temperature	t_2 [°C]										
	power at shaft / motor rating	$\dot{P}_{K/Mot}$ [kW]										
	power, idling $p_1 = p_2 = 1,0 \text{ bar}$	P_{Leer} [kW]										
	reduced moment of inertia	J [kgm ²]										
	Lp(A) w/o.h./w.h.	[dBA]										
	3,00	flow at inlet	\dot{V}_1 [m ³ /h]									
		compressor speed	nH [1/min]									
motor speed		nM [1/min]										
discharge temperature		t_2 [°C]										
power at shaft / motor rating		$\dot{P}_{K/Mot}$ [kW]										
power, idling $p_1 = p_2 = 1,0 \text{ bar}$		P_{Leer} [kW]										
reduced moment of inertia		J [kgm ²]										
Lp(A) w/o.h./w.h.		[dBA]										
3,25		flow at inlet	\dot{V}_1 [m ³ /h]									
		compressor speed	nH [1/min]									
	motor speed	nM [1/min]										
	discharge temperature	t_2 [°C]										
	power at shaft / motor rating	$\dot{P}_{K/Mot}$ [kW]										
	power, idling $p_1 = p_2 = 1,0 \text{ bar}$	P_{Leer} [kW]										
	reduced moment of inertia	J [kgm ²]										
	Lp(A) w/o.h./w.h.	[dBA]										
	3,50	flow at inlet	\dot{V}_1 [m ³ /h]									
		compressor speed	nH [1/min]									
motor speed		nM [1/min]										
discharge temperature		t_2 [°C]										
power at shaft / motor rating		$\dot{P}_{K/Mot}$ [kW]										
power, idling $p_1 = p_2 = 1,0 \text{ bar}$		P_{Leer} [kW]										
reduced moment of inertia		J [kgm ²]										
Lp(A) w/o.h./w.h.		[dBA]										

Performance data based on the compression of air ($p_1= 1.0$ bar, $t_1= 20$ °C)

Discharge pressure p_2 [bar gauge]	Compressor size gear ratio	VM 45												
		i	i_4	i_5	i_6	i_7	i_8	i_9	i_{10}	i_{11}	i_{12}			
0,75	flow at inlet	\dot{V}_1	[m ³ /h]											
	compressor speed	nH	[1/min]											
	motor speed	nM	[1/min]											
	discharge temperature	t_2	[°C]											
	power at shaft / motor rating	$\dot{P}_{K/Mot}$	[kW]											
	power, idling $p_1 = p_2 = 1,0$ bar	\dot{P}_{Leer}	[kW]											
	reduced moment of inertia	J	[kgm ²]											
	Lp(A) w/o.h./w.h.		[dBA]											
1,00	flow at inlet	\dot{V}_1	[m ³ /h]											
	compressor speed	nH	[1/min]											
	motor speed	nM	[1/min]											
	discharge temperature	t_2	[°C]											
	power at shaft / motor rating	$\dot{P}_{K/Mot}$	[kW]											
	power, idling $p_1 = p_2 = 1,0$ bar	\dot{P}_{Leer}	[kW]											
	reduced moment of inertia	J	[kgm ²]											
	Lp(A) w/o.h./w.h.		[dBA]											
1,25	flow at inlet	\dot{V}_1	[m ³ /h]											
	compressor speed	nH	[1/min]											
	motor speed	nM	[1/min]											
	discharge temperature	t_2	[°C]											
	power at shaft / motor rating	$\dot{P}_{K/Mot}$	[kW]											
	power, idling $p_1 = p_2 = 1,0$ bar	\dot{P}_{Leer}	[kW]											
	reduced moment of inertia	J	[kgm ²]											
	Lp(A) w/o.h./w.h.		[dBA]											
1,50	flow at inlet	\dot{V}_1	[m ³ /h]											
	compressor speed	nH	[1/min]											
	motor speed	nM	[1/min]											
	discharge temperature	t_2	[°C]											
	power at shaft / motor rating	$\dot{P}_{K/Mot}$	[kW]											
	power, idling $p_1 = p_2 = 1,0$ bar	\dot{P}_{Leer}	[kW]											
	reduced moment of inertia	J	[kgm ²]											
	Lp(A) w/o.h./w.h.		[dBA]											
1,75	flow at inlet	\dot{V}_1	[m ³ /h]											
	compressor speed	nH	[1/min]											
	motor speed	nM	[1/min]											
	discharge temperature	t_2	[°C]											
	power at shaft / motor rating	$\dot{P}_{K/Mot}$	[kW]											
	power, idling $p_1 = p_2 = 1,0$ bar	\dot{P}_{Leer}	[kW]											
	reduced moment of inertia	J	[kgm ²]											
	Lp(A) w/o.h./w.h.		[dBA]											
2,00	flow at inlet	\dot{V}_1	[m ³ /h]	1016	1183	1377	1605	1848	2117	2464	2766	3161		
	compressor speed	nH	[1/min]	4655	5198	5823	6555	7331	8183	9272	10213	11431		
	motor speed	nM	[1/min]	2950	2950	2950	2950	2950	2950	2950	2950	2950		
	discharge temperature	t_2	[°C]	176	172	168	165	163	162	163	164	160		
	power at shaft / motor rating	$\dot{P}_{K/Mot}$	[kW]	57 / 75	64 / 90	73 / 90	83 / 110	94 / 132	107 / 132	125 / 160	141 / 200	164 / 200		
	power, idling $p_1 = p_2 = 1,0$ bar	\dot{P}_{Leer}	[kW]	28,5	31	35,6	42,2	49,6	57,7	68	78,2	115		
	reduced moment of inertia	J	[kgm ²]	0,86	1,004	1,19	1,424	1,704	2,034	2,501	2,95	3,57		
	Lp(A) w/o.h./w.h.		[dBA]	97 / 77	97 / 78	98 / 78	98 / 78	99 / 78	100 / 78	102 / 80	103 / 80	103 / 83	104 / 83	
2,25	flow at inlet	\dot{V}_1	[m ³ /h]	1000	1168	1361	1589	1832	2102	2448	2751	3146		
	compressor speed	nH	[1/min]	4655	5198	5823	6555	7331	8183	9272	10213	11431		
	motor speed	nM	[1/min]	2950	2950	2950	2950	2950	2950	2950	2950	2950		
	discharge temperature	t_2	[°C]	188	187	182	178	175	174	173	174	169		
	power at shaft / motor rating	$\dot{P}_{K/Mot}$	[kW]	62 / 75	70 / 90	79 / 110	89 / 110	101 / 132	115 / 132	133 / 160	150 / 200	174 / 200		
	power, idling $p_1 = p_2 = 1,0$ bar	\dot{P}_{Leer}	[kW]	28,5	31	35,6	42,2	49,6	57,7	68	78,2	115		
	reduced moment of inertia	J	[kgm ²]	0,86	1,004	1,19	1,424	1,704	2,034	2,501	2,95	3,57		
	Lp(A) w/o.h./w.h.		[dBA]	97 / 77	97 / 78	98 / 78	98 / 78	99 / 78	100 / 78	102 / 80	103 / 84	104 / 84		
2,50	flow at inlet	\dot{V}_1	[m ³ /h]	994	1152	1345	1573	1817	2086	2432	2735	3107		
	compressor speed	nH	[1/min]	4655	5198	5823	6555	7331	8183	9272	10213	11431		
	motor speed	nM	[1/min]	2950	2950	2950	2950	2950	2950	2950	2950	2950		
	discharge temperature	t_2	[°C]	201	203	197	192	188	186	185	184	187		
	power at shaft / motor rating	$\dot{P}_{K/Mot}$	[kW]	67 / 90	75 / 90	85 / 110	96 / 132	109 / 132	123 / 160	142 / 200	160 / 200	184 / 250		
	power, idling $p_1 = p_2 = 1,0$ bar	\dot{P}_{Leer}	[kW]	44,4	31	35,6	42,2	49,6	57,7	68	78,2	115		
	reduced moment of inertia	J	[kgm ²]	0,86	1,004	1,19	1,424	1,704	2,034	2,501	2,95	3,57		
	Lp(A) w/o.h./w.h.		[dBA]	97 / 77	97 / 78	98 / 78	99 / 78	99 / 78	100 / 78	100 / 78	102 / 80	103 / 84	104 / 84	
2,75	flow at inlet	\dot{V}_1	[m ³ /h]	980	1148	1341	1569	1801	2070	2417	2719	3091		
	compressor speed	nH	[1/min]	4655	5198	5823	6555	7331	8183	9272	10213	11431		
	motor speed	nM	[1/min]	2950	2950	2950	2950	2950	2950	2950	2950	2950		
	discharge temperature	t_2	[°C]	214	216	210	205	201	198	196	195	196		
	power at shaft / motor rating	$\dot{P}_{K/Mot}$	[kW]	71 / 90	80 / 110	91 / 110	104 / 132	116 / 160	131 / 160	151 / 200	169 / 200	194 / 250		
	power, idling $p_1 = p_2 = 1,0$ bar	\dot{P}_{Leer}	[kW]	44,4	42,7	49,2	57,8	49,6	57,7	68	78,2	115		
	reduced moment of inertia	J	[kgm ²]	0,86	1,004	1,19	1,424	1,704	2,034	2,501	2,95	3,57		
	Lp(A) w/o.h./w.h.		[dBA]	97 / 77	97 / 78	98 / 78	99 / 78	100 / 78	102 / 80	102 / 80	104 / 84	105 / 85		
3,00	flow at inlet	\dot{V}_1	[m ³ /h]	967	1134	1328	1556	1799	2068	2401	2703	3075		
	compressor speed	nH	[1/min]	4655	5198	5823	6555	7331	8183	9272	10213	11431		
	motor speed	nM	[1/min]	2950	2950	2950	2950	2950	2950	2950	2950	2950		
	discharge temperature	t_2	[°C]	228	229	222	216	212	210	208	206	202		
	power at shaft / motor rating	$\dot{P}_{K/Mot}$	[kW]	75 / 90	84 / 110	95 / 132	109 / 132	123 / 160	140 / 200	160 / 200	179 / 200	204 / 250		
	power, idling $p_1 = p_2 = 1,0$ bar	\dot{P}_{Leer}	[kW]	44,4	42,7	49,2	57,8	68	78,6	68	78,2	115		
	reduced moment of inertia	J	[kgm ²]	0,86	1,004	1,19	1,424	1,704	2,034	2,501	2,95	3,57		
	Lp(A) w/o.h./w.h.		[dBA]	98 / 78	98 / 78	98 / 78	99 / 78	101 / 78	103 / 80	103 / 80	105 / 84	106 / 85		
3,25	flow at inlet	\dot{V}_1	[m ³ /h]	954	1108	1315	1543	1786	2055	2402	2704	3059		
	compressor speed	nH	[1/min]	4655	5198	5823	6555	7331	8183	9272	10213	11431		
	motor speed	nM	[1/min]	2950	2950	2950	2950	2950	2950	2950	2950	2950		
	discharge temperature	t_2	[°C]	242	250	234	227	223	219	217	216	209		
	power at shaft / motor rating	$\dot{P}_{K/Mot}$	[kW]	79 / 110	93 / 132	100 / 132	114 / 132	129 / 160	146 / 200	168 / 200	189 / 250	216 / 250		
	power, idling $p_1 = p_2 = 1,0$ bar	\dot{P}_{Leer}	[kW]	44,4	42,7	49,2	57,8	68	78,6	92,5	105	115		
	reduced moment of inertia	J	[kgm ²]	0,86	1,004	1,19	1,424	1,704	2,034	2,501	2,95	3,57		
	Lp(A) w/o.h./w.h.		[dBA]	98 / 78	99 / 78	98 / 78	100 / 78	101 / 78	103 / 80	103 / 80	106 / 84	107 / 85		
3,50	flow at inlet	\dot{V}_1	[m ³ /h]			1302	1529	1773	2042	2389	2691	3063		
	compressor speed	nH	[1/min]			5823	6555	7331	8183	9272	10213	11431		
	motor speed	nM	[1/min]			2950	2950	2950	2950	2950	2950	2950		
	discharge temperature	t_2	[°C]			246	239	233	229	226	225	217		
	power at shaft / motor rating	$\dot{P}_{K/Mot}$	[kW]			105 / 132	119 / 160	134 / 160	152 / 200	175 / 200	196 / 250	215 / 250		
	power, idling $p_1 = p_2 = 1,0$ bar	\dot{P}_{Leer}	[kW]			49,2	57,8	68	78,6	92,5	105	166		
	reduced moment of inertia	J	[kgm ²]			1,19	1,424	1,704	2,034	2,501	2,95	3,57		
	Lp(A) w/o.h./w.h.		[dBA]			99 / 78	100 / 78	101 / 78	103 / 80	103 / 80	107 / 84	108 / 85		

Performance data based on the compression of air ($p_1 = 1.0 \text{ bar}$, $t_1 = 20 \text{ }^\circ\text{C}$)

Discharge pressure p_2 [bar gauge]	Compressor size		VML 60									
	gear ratio		i	i_3	i_4	i_5	i_6	i_7	i_8	i_9	i_{10}	$i_{10/11}$
0,75	flow at inlet	V_1	[m ³ /h]	1663	1905	2182	2504	2882	3287	3735	4313	4554
	compressor speed	nH	[1/min]	4180	4655	5198	5823	6555	7331	8183	9272	9723
	motor speed	nM	[1/min]	2950	2950	2950	2950	2950	2950	2950	2950	2950
	discharge temperature	t_2	[°C]	85	84	83	83	84	85	86	89	91
	power at shaft / motor rating	$\dot{P}_{K/Mot}$	[kW]	37,8 / 55	42,6 / 55	48,3 / 75	56 / 75	65 / 90	75 / 90	87 / 110	105 / 132	113 / 132
	power, idling $p_1 = p_2 = 1,0 \text{ bar}$	P_{Leer}	[kW]	19,1	22	25,6	30,1	35,9	42,9	52	69	76
	reduced moment of inertia	J	[kgm ²]	1	1,2	1,4	1,8	2,2	2,6	3,2	3,9	4,4
	Lp(A) w/o.h./w.h.		[dBA]	93 / 75	94 / 76	96 / 76	97 / 81	99 / 81	100 / 82	101 / 84	102 / 85	103 / 85
	flow at inlet	V_1	[m ³ /h]	1631	1872	2150	2471	2850	3254	3703	4280	4521
	compressor speed	nH	[1/min]	4180	4655	5198	5823	6555	7331	8183	9272	9723
motor speed	nM	[1/min]	2950	2950	2950	2950	2950	2950	2950	2950	2950	
discharge temperature	t_2	[°C]	105	102	101	100	99	100	101	103	104	
power at shaft / motor rating	$\dot{P}_{K/Mot}$	[kW]	48,3 / 75	54 / 75	61 / 75	69 / 90	79 / 110	91 / 110	105 / 132	124 / 132	133 / 160	
power, idling $p_1 = p_2 = 1,0 \text{ bar}$	P_{Leer}	[kW]	19,1	22	25,6	30,1	35,9	42,9	52	69	76	
reduced moment of inertia	J	[kgm ²]	1	1,2	1,4	1,8	2,2	2,6	3,2	3,9	4,4	
Lp(A) w/o.h./w.h.		[dBA]	93 / 75	94 / 76	96 / 77	97 / 81	99 / 81	100 / 82	101 / 84	102 / 85	103 / 85	
flow at inlet	V_1	[m ³ /h]	1616	1858	2135	2439	2817	3222	3670	4248	4489	
compressor speed	nH	[1/min]	4180	4655	5198	5823	6555	7331	8183	9272	9723	
motor speed	nM	[1/min]	2950	2950	2950	2950	2950	2950	2950	2950	2950	
discharge temperature	t_2	[°C]	121	119	118	117	116	115	115	117	118	
power at shaft / motor rating	$\dot{P}_{K/Mot}$	[kW]	58 / 75	65 / 90	73 / 90	83 / 110	95 / 132	108 / 132	123 / 160	144 / 160	154 / 200	
power, idling $p_1 = p_2 = 1,0 \text{ bar}$	P_{Leer}	[kW]	22,6	26,3	30,8	30,1	35,9	42,9	52	69	76	
reduced moment of inertia	J	[kgm ²]	1	1,2	1,4	1,8	2,2	2,6	3,2	3,9	4,4	
Lp(A) w/o.h./w.h.		[dBA]	94 / 77	95 / 78	97 / 79	98 / 81	100 / 82	101 / 83	102 / 84	103 / 85	104 / 85	
flow at inlet	V_1	[m ³ /h]	1591	1832	2110	2431	2810	3214	3638	4215	4457	
compressor speed	nH	[1/min]	4180	4655	5198	5823	6555	7331	8183	9272	9723	
motor speed	nM	[1/min]	2950	2950	2950	2950	2950	2950	2950	2950	2950	
discharge temperature	t_2	[°C]	128	135	133	131	131	131	131	131	132	
power at shaft / motor rating	$\dot{P}_{K/Mot}$	[kW]	66 / 90	74 / 90	84 / 110	95 / 132	109 / 132	125 / 160	141 / 200	164 / 200	175 / 200	
power, idling $p_1 = p_2 = 1,0 \text{ bar}$	P_{Leer}	[kW]	22,6	26,3	30,8	36,4	43,6	53	63	76		
reduced moment of inertia	J	[kgm ²]	1	1,2	1,4	1,8	2,2	2,6	3,2	3,9	4,4	
Lp(A) w/o.h./w.h.		[dBA]	95 / 76	95 / 80	97 / 80	98 / 81	100 / 82	101 / 83	102 / 84	103 / 85	104 / 85	
flow at inlet	V_1	[m ³ /h]	1565	1807	2084	2406	2784	3189	3637	4215	4424	
compressor speed	nH	[1/min]	4180	4655	5198	5823	6555	7331	8183	9272	9723	
motor speed	nM	[1/min]	2950	2950	2950	2950	2950	2950	2950	2950	2950	
discharge temperature	t_2	[°C]	156	152	149	146	145	144	145	146	147	
power at shaft / motor rating	$\dot{P}_{K/Mot}$	[kW]	75 / 90	83 / 110	94 / 132	106 / 132	121 / 160	138 / 160	158 / 200	186 / 200	196 / 250	
power, idling $p_1 = p_2 = 1,0 \text{ bar}$	P_{Leer}	[kW]	22,6	26,3	30,8	36,4	43,6	53	63	76		
reduced moment of inertia	J	[kgm ²]	1	1,2	1,4	1,8	2,2	2,6	3,2	3,9	4,4	
Lp(A) w/o.h./w.h.		[dBA]	96 / 78	96 / 81	98 / 81	99 / 82	101 / 83	102 / 84	103 / 84	104 / 85	105 / 86	
flow at inlet	V_1	[m ³ /h]	1540	1781	2059	2380	2759	3163	3612	4189	4430	
compressor speed	nH	[1/min]	4180	4655	5198	5823	6555	7331	8183	9272	9723	
motor speed	nM	[1/min]	2950	2950	2950	2950	2950	2950	2950	2950	2950	
discharge temperature	t_2	[°C]	176	170	165	162	159	158	158	159	160	
power at shaft / motor rating	$\dot{P}_{K/Mot}$	[kW]	83 / 110	93 / 132	104 / 132	117 / 160	134 / 160	152 / 200	173 / 200	202 / 250	214 / 250	
power, idling $p_1 = p_2 = 1,0 \text{ bar}$	P_{Leer}	[kW]	22,6	26,3	30,8	36,4	43,6	53	63	76		
reduced moment of inertia	J	[kgm ²]	1	1,2	1,4	1,8	2,2	2,6	3,2	3,9	4,4	
Lp(A) w/o.h./w.h.		[dBA]	96 / 78	97 / 82	98 / 82	99 / 82	102 / 84	103 / 84	105 / 84	105 / 85	106 / 86	
flow at inlet	V_1	[m ³ /h]										
compressor speed	nH	[1/min]										
motor speed	nM	[1/min]										
discharge temperature	t_2	[°C]										
power at shaft / motor rating	$\dot{P}_{K/Mot}$	[kW]										
power, idling $p_1 = p_2 = 1,0 \text{ bar}$	P_{Leer}	[kW]										
reduced moment of inertia	J	[kgm ²]										
Lp(A) w/o.h./w.h.		[dBA]										
flow at inlet	V_1	[m ³ /h]										
compressor speed	nH	[1/min]										
motor speed	nM	[1/min]										
discharge temperature	t_2	[°C]										
power at shaft / motor rating	$\dot{P}_{K/Mot}$	[kW]										
power, idling $p_1 = p_2 = 1,0 \text{ bar}$	P_{Leer}	[kW]										
reduced moment of inertia	J	[kgm ²]										
Lp(A) w/o.h./w.h.		[dBA]										
flow at inlet	V_1	[m ³ /h]										
compressor speed	nH	[1/min]										
motor speed	nM	[1/min]										
discharge temperature	t_2	[°C]										
power at shaft / motor rating	$\dot{P}_{K/Mot}$	[kW]										
power, idling $p_1 = p_2 = 1,0 \text{ bar}$	P_{Leer}	[kW]										
reduced moment of inertia	J	[kgm ²]										
Lp(A) w/o.h./w.h.		[dBA]										
flow at inlet	V_1	[m ³ /h]										
compressor speed	nH	[1/min]										
motor speed	nM	[1/min]										
discharge temperature	t_2	[°C]										
power at shaft / motor rating	$\dot{P}_{K/Mot}$	[kW]										
power, idling $p_1 = p_2 = 1,0 \text{ bar}$	P_{Leer}	[kW]										
reduced moment of inertia	J	[kgm ²]										
Lp(A) w/o.h./w.h.		[dBA]										

Performance data based on the compression of air ($p_1=1.0$ bar, $t_1=20$ °C)

Discharge pressure p_2 [bar gauge]	Compressor size gear ratio	VM 75									
		i [-]	i_3	i_4	i_5	i_6	i_7	i_8	i_9	i_{10}	i_{11}
0,75	flow at inlet	\dot{V}_1 [m³/h]									
	compressor speed	nH [1/min]									
	motor speed	nM [1/min]									
	discharge temperature	t_2 [°C]									
	power at shaft / motor rating	$\dot{P}_{K/Mot}$ [kW]									
	power, idling $p_1=p_2=1,0$ bar	\dot{P}_{Leer} [kW]									
	reduced moment of inertia Lp(A) w/o.h./w.h.	J [kgm²] [dBA]									
1,00	flow at inlet	\dot{V}_1 [m³/h]									
	compressor speed	nH [1/min]									
	motor speed	nM [1/min]									
	discharge temperature	t_2 [°C]									
	power at shaft / motor rating	$\dot{P}_{K/Mot}$ [kW]									
	power, idling $p_1=p_2=1,0$ bar	\dot{P}_{Leer} [kW]									
	reduced moment of inertia Lp(A) w/o.h./w.h.	J [kgm²] [dBA]									
1,25	flow at inlet	\dot{V}_1 [m³/h]									
	compressor speed	nH [1/min]									
	motor speed	nM [1/min]									
	discharge temperature	t_2 [°C]									
	power at shaft / motor rating	$\dot{P}_{K/Mot}$ [kW]									
	power, idling $p_1=p_2=1,0$ bar	\dot{P}_{Leer} [kW]									
	reduced moment of inertia Lp(A) w/o.h./w.h.	J [kgm²] [dBA]									
1,50	flow at inlet	\dot{V}_1 [m³/h]									
	compressor speed	nH [1/min]									
	motor speed	nM [1/min]									
	discharge temperature	t_2 [°C]									
	power at shaft / motor rating	$\dot{P}_{K/Mot}$ [kW]									
	power, idling $p_1=p_2=1,0$ bar	\dot{P}_{Leer} [kW]									
	reduced moment of inertia Lp(A) w/o.h./w.h.	J [kgm²] [dBA]									
1,75	flow at inlet	\dot{V}_1 [m³/h]									
	compressor speed	nH [1/min]									
	motor speed	nM [1/min]									
	discharge temperature	t_2 [°C]									
	power at shaft / motor rating	$\dot{P}_{K/Mot}$ [kW]									
	power, idling $p_1=p_2=1,0$ bar	\dot{P}_{Leer} [kW]									
	reduced moment of inertia Lp(A) w/o.h./w.h.	J [kgm²] [dBA]									
2,00	flow at inlet	\dot{V}_1 [m³/h]	1950	2235	2586	2973	3381	3867	4497	5027	5655
	compressor speed	nH [1/min]	4174	4643	5216	5844	6502	7278	8275	9160	10198
	motor speed	nM [1/min]	2950	2950	2950	2950	2950	2950	2950	2950	2950
	discharge temperature	t_2 [°C]	167	164	162	161	161	162	163	160	163
	power at shaft / motor rating	$\dot{P}_{K/Mot}$ [kW]	102 / 132	115 / 132	131 / 160	149 / 200	169 / 200	194 / 250	229 / 315	262 / 315	303 / 355
	power, idling $p_1=p_2=1,0$ bar	\dot{P}_{Leer} [kW]	44,9	53	61,2	69,6	81,6	95,2	113	186	223
	reduced moment of inertia Lp(A) w/o.h./w.h.	J [kgm²] [dBA]	2,66 97 / 77	3,05 98 / 78	3,57 100 / 79	4,18 101 / 80	4,88 101 / 80	5,76 102 / 81	7,01 103 / 84	8,41 104 / 84	9,89 105 / 85
2,25	flow at inlet	\dot{V}_1 [m³/h]	1928	2213	2564	2951	3360	3845	4475	5005	5634
	compressor speed	nH [1/min]	4174	4643	5216	5844	6502	7278	8275	9160	10198
	motor speed	nM [1/min]	2950	2950	2950	2950	2950	2950	2950	2950	2950
	discharge temperature	t_2 [°C]	181	178	175	173	172	172	173	169	172
	power at shaft / motor rating	$\dot{P}_{K/Mot}$ [kW]	111 / 132	124 / 160	141 / 200	160 / 200	181 / 250	208 / 250	243 / 315	277 / 315	320 / 355
	power, idling $p_1=p_2=1,0$ bar	\dot{P}_{Leer} [kW]	44,9	53	61,2	69,6	81,6	95,2	113	186	223
	reduced moment of inertia Lp(A) w/o.h./w.h.	J [kgm²] [dBA]	2,66 97 / 77	3,05 98 / 78	3,57 100 / 79	4,18 101 / 80	4,88 101 / 80	5,76 102 / 81	7,01 103 / 84	8,41 104 / 84	9,89 105 / 85
2,50	flow at inlet	\dot{V}_1 [m³/h]	1906	2192	2542	2930	3338	3824	4454	4984	5612
	compressor speed	nH [1/min]	4174	4643	5216	5844	6502	7278	8275	9160	10198
	motor speed	nM [1/min]	2950	2950	2950	2950	2950	2950	2950	2950	2950
	discharge temperature	t_2 [°C]	196	192	188	185	184	183	183	179	181
	power at shaft / motor rating	$\dot{P}_{K/Mot}$ [kW]	120 / 160	134 / 160	151 / 200	172 / 200	194 / 250	221 / 250	258 / 315	293 / 315	337 / 355
	power, idling $p_1=p_2=1,0$ bar	\dot{P}_{Leer} [kW]	44,9	53	61,2	69,6	81,6	95,2	113	186	223
	reduced moment of inertia Lp(A) w/o.h./w.h.	J [kgm²] [dBA]	2,66 97 / 77	3,05 98 / 78	3,57 100 / 79	4,18 101 / 80	4,88 101 / 80	5,76 102 / 81	7,01 104 / 84	8,41 105 / 84	9,89 105 / 85
2,75	flow at inlet	\dot{V}_1 [m³/h]	1900	2186	2521	2908	3317	3802	4432	4962	5591
	compressor speed	nH [1/min]	4174	4643	5216	5844	6502	7278	8275	9160	10198
	motor speed	nM [1/min]	2950	2950	2950	2950	2950	2950	2950	2950	2950
	discharge temperature	t_2 [°C]	209	205	201	197	195	194	194	194	196
	power at shaft / motor rating	$\dot{P}_{K/Mot}$ [kW]	128 / 160	144 / 200	162 / 200	183 / 250	206 / 250	235 / 315	273 / 315	309 / 355	355 / 400
	power, idling $p_1=p_2=1,0$ bar	\dot{P}_{Leer} [kW]	57,1	68	78,9	89,6	105	121	143	186	223
	reduced moment of inertia Lp(A) w/o.h./w.h.	J [kgm²] [dBA]	2,66 97 / 77	3,05 98 / 78	3,57 100 / 79	4,18 102 / 81	4,88 102 / 81	5,76 103 / 81	7,01 105 / 84	8,41 105 / 85	9,89 106 / 85
3,00	flow at inlet	\dot{V}_1 [m³/h]	1882	2168	2518	2906	3295	3781	4411	4940	5569
	compressor speed	nH [1/min]	4174	4643	5216	5844	6502	7278	8275	9160	10198
	motor speed	nM [1/min]	2950	2950	2950	2950	2950	2950	2950	2950	2950
	discharge temperature	t_2 [°C]	221	216	212	209	207	205	204	201	203
	power at shaft / motor rating	$\dot{P}_{K/Mot}$ [kW]	134 / 160	151 / 200	172 / 200	195 / 250	219 / 250	248 / 315	288 / 315	326 / 355	373 / 500
	power, idling $p_1=p_2=1,0$ bar	\dot{P}_{Leer} [kW]	57,1	68	78,9	91,1	105	121	143	186	223
	reduced moment of inertia Lp(A) w/o.h./w.h.	J [kgm²] [dBA]	2,66 97 / 77	3,05 98 / 78	3,57 101 / 81	4,18 102 / 81	4,88 103 / 82	5,76 103 / 82	7,01 105 / 84	8,41 105 / 85	9,89 106 / 86
3,25	flow at inlet	\dot{V}_1 [m³/h]	1864	2150	2500	2880	3296	3782	4412	4919	5547
	compressor speed	nH [1/min]	4174	4643	5216	5844	6502	7278	8275	9160	10198
	motor speed	nM [1/min]	2950	2950	2950	2950	2950	2950	2950	2950	2950
	discharge temperature	t_2 [°C]	233	227	222	219	217	215	215	208	210
	power at shaft / motor rating	$\dot{P}_{K/Mot}$ [kW]	141 / 200	158 / 200	180 / 250	204 / 250	230 / 315	262 / 315	305 / 366	342 / 400	391 / 500
	power, idling $p_1=p_2=1,0$ bar	\dot{P}_{Leer} [kW]	57,1	68	78,9	91,1	105	121	143	186	223
	reduced moment of inertia Lp(A) w/o.h./w.h.	J [kgm²] [dBA]	2,66 98 / 78	3,05 99 / 79	3,57 102 / 81	4,18 102 / 81	4,88 103 / 82	5,76 104 / 82	7,01 105 / 84	8,41 106 / 85	9,89 106 / 86
3,50	flow at inlet	\dot{V}_1 [m³/h]	1846	2132	2482	2870	3278	3764	4394	4924	5552
	compressor speed	nH [1/min]	4174	4643	5216	5844	6502	7278	8275	9160	10198
	motor speed	nM [1/min]	2950	2950	2950	2950	2950	2950	2950	2950	2950
	discharge temperature	t_2 [°C]	246	239	233	229	226	224	223	216	217
	power at shaft / motor rating	$\dot{P}_{K/Mot}$ [kW]	148 / 200	166 / 200	188 / 250	213 / 250	239 / 315	272 / 315	316 / 355	357 / 400	407 / 500
	power, idling $p_1=p_2=1,0$ bar	\dot{P}_{Leer} [kW]	57,1	68	78,9	91,1	105	121	143	186	223
	reduced moment of inertia Lp(A) w/o.h./w.h.	J [kgm²] [dBA]	2,66 98 / 78	3,05 99 / 79	3,57 100 / 79	4,18 102 / 81	4,88 103 / 82	5,76 104 / 82	7,01 106 / 84	8,41 106 / 85	9,89 107 / 86

Performance data based on the compression of air ($p_1 = 1.0 \text{ bar}$, $t_1 = 20 \text{ }^\circ\text{C}$)

Discharge pressure p_2 [bar gauge]	Compressor size		VM 85									
	gear ratio		i	i_8	i_9	i_{10}	i_{11}	i_{12}	i_{13}	i_7	i_8	i_9
0,75	flow at inlet	V_1	[m ³ /h]									
	compressor speed	nH	[1/min]									
	motor speed	nM	[1/min]									
	discharge temperature	t_2	[°C]									
	power at shaft / motor rating	$\dot{P}_{K/Mot}$	[kW]									
	power, idling $p_1 = p_2 = 1,0 \text{ bar}$	\dot{P}_{Leer}	[kW]									
	reduced moment of inertia Lp(A) w/o.h./w.h.	J	[kgm ²]									
			[dBA]									
1,00	flow at inlet	V_1	[m ³ /h]									
	compressor speed	nH	[1/min]									
	motor speed	nM	[1/min]									
	discharge temperature	t_2	[°C]									
	power at shaft / motor rating	$\dot{P}_{K/Mot}$	[kW]									
	power, idling $p_1 = p_2 = 1,0 \text{ bar}$	\dot{P}_{Leer}	[kW]									
	reduced moment of inertia Lp(A) w/o.h./w.h.	J	[kgm ²]									
			[dBA]									
1,25	flow at inlet	V_1	[m ³ /h]									
	compressor speed	nH	[1/min]									
	motor speed	nM	[1/min]									
	discharge temperature	t_2	[°C]									
	power at shaft / motor rating	$\dot{P}_{K/Mot}$	[kW]									
	power, idling $p_1 = p_2 = 1,0 \text{ bar}$	\dot{P}_{Leer}	[kW]									
	reduced moment of inertia Lp(A) w/o.h./w.h.	J	[kgm ²]									
			[dBA]									
1,50	flow at inlet	V_1	[m ³ /h]									
	compressor speed	nH	[1/min]									
	motor speed	nM	[1/min]									
	discharge temperature	t_2	[°C]									
	power at shaft / motor rating	$\dot{P}_{K/Mot}$	[kW]									
	power, idling $p_1 = p_2 = 1,0 \text{ bar}$	\dot{P}_{Leer}	[kW]									
	reduced moment of inertia Lp(A) w/o.h./w.h.	J	[kgm ²]									
			[dBA]									
1,75	flow at inlet	V_1	[m ³ /h]									
	compressor speed	nH	[1/min]									
	motor speed	nM	[1/min]									
	discharge temperature	t_2	[°C]									
	power at shaft / motor rating	$\dot{P}_{K/Mot}$	[kW]									
	power, idling $p_1 = p_2 = 1,0 \text{ bar}$	\dot{P}_{Leer}	[kW]									
	reduced moment of inertia Lp(A) w/o.h./w.h.	J	[kgm ²]									
			[dBA]									
2,00	flow at inlet	V_1	[m ³ /h]	2498	2949	3352	3827	4395	5039	5145	5834	6729
	compressor speed	nH	[1/min]	3626	4123	4564	5082	5696	6387	6502	7278	8275
	motor speed	nM	[1/min]	1470	1470	1470	1470	1470	1470	2950	2950	2950
	discharge temperature	t_2	[°C]	159	155	153	152	151	151	151	153	157
	power at shaft / motor rating	$\dot{P}_{K/Mot}$	[kW]	129 / 160	147 / 200	165 / 200	186 / 250	212 / 250	243 / 315	249 / 315	287 / 315	339 / 400
	power, idling $p_1 = p_2 = 1,0 \text{ bar}$	\dot{P}_{Leer}	[kW]	54	62	71	83	95	111	115	138	171
	reduced moment of inertia Lp(A) w/o.h./w.h.	J	[kgm ²]	10,6	13,1	15,7	18,9	23,2	28,6	8,79	10,6	13,1
			[dBA]	99 / 79	101 / 81	102 / 81	103 / 82	104 / 82	106 / 85	107 / 85	109 / 86	112 / 87
2,25	flow at inlet	V_1	[m ³ /h]	2468	2920	3322	3798	4366	5010	5116	5805	6700
	compressor speed	nH	[1/min]	3626	4123	4564	5082	5696	6387	6502	7278	8275
	motor speed	nM	[1/min]	1470	1470	1470	1470	1470	2950	2950	2950	2950
	discharge temperature	t_2	[°C]	174	169	167	164	163	162	163	164	167
	power at shaft / motor rating	$\dot{P}_{K/Mot}$	[kW]	141 / 200	161 / 200	180 / 250	202 / 250	230 / 315	263 / 315	268 / 315	308 / 355	363 / 400
	power, idling $p_1 = p_2 = 1,0 \text{ bar}$	\dot{P}_{Leer}	[kW]	54	62	71	83	95	111	115	138	171
	reduced moment of inertia Lp(A) w/o.h./w.h.	J	[kgm ²]	10,6	13,1	15,7	18,9	23,2	28,6	8,79	10,6	13,1
			[dBA]	99 / 79	101 / 80	102 / 81	103 / 82	104 / 82	106 / 85	107 / 85	109 / 86	112 / 87
2,50	flow at inlet	V_1	[m ³ /h]	2456	2907	3293	3768	4336	4980	5086	5775	6671
	compressor speed	nH	[1/min]	3626	4123	4564	5082	5696	6387	6502	7278	8275
	motor speed	nM	[1/min]	1470	1470	1470	1470	1470	2950	2950	2950	2950
	discharge temperature	t_2	[°C]	188	183	180	177	175	174	174	175	177
	power at shaft / motor rating	$\dot{P}_{K/Mot}$	[kW]	153 / 200	176 / 200	195 / 250	218 / 250	248 / 315	282 / 315	288 / 315	329 / 355	386 / 500
	power, idling $p_1 = p_2 = 1,0 \text{ bar}$	\dot{P}_{Leer}	[kW]	68	80	93	108	127	151	154	184	227
	reduced moment of inertia Lp(A) w/o.h./w.h.	J	[kgm ²]	10,6	13,1	15,7	18,9	23,2	28,6	8,79	10,6	13,1
			[dBA]	99 / 79	101 / 80	102 / 81	104 / 82	105 / 83	106 / 85	108 / 86	112 / 87	114 / 88
2,75	flow at inlet	V_1	[m ³ /h]	2431	2882	3285	3760	4307	4951	5057	5746	6641
	compressor speed	nH	[1/min]	3626	4123	4564	5082	5696	6387	6502	7278	8275
	motor speed	nM	[1/min]	1470	1470	1470	1470	1470	2950	2950	2950	2950
	discharge temperature	t_2	[°C]	201	196	193	190	188	186	186	186	188
	power at shaft / motor rating	$\dot{P}_{K/Mot}$	[kW]	163 / 200	187 / 250	209 / 250	236 / 315	266 / 315	302 / 355	308 / 355	351 / 400	411 / 500
	power, idling $p_1 = p_2 = 1,0 \text{ bar}$	\dot{P}_{Leer}	[kW]	68	80	93	108	127	151	154	184	227
	reduced moment of inertia Lp(A) w/o.h./w.h.	J	[kgm ²]	10,6	13,1	15,7	18,9	23,2	28,6	8,79	10,6	13,1
			[dBA]	98 / 79	101 / 81	102 / 81	104 / 82	105 / 83	106 / 85	108 / 86	112 / 87	114 / 88
3,00	flow at inlet	V_1	[m ³ /h]	2407	2858	3261	3736	4304	4921	5028	5717	6612
	compressor speed	nH	[1/min]	3626	4123	4564	5082	5696	6387	6502	7278	8275
	motor speed	nM	[1/min]	1470	1470	1470	1470	1470	2950	2950	2950	2950
	discharge temperature	t_2	[°C]	215	208	204	201	199	198	197	197	199
	power at shaft / motor rating	$\dot{P}_{K/Mot}$	[kW]	174 / 200	199 / 250	222 / 250	250 / 315	284 / 315	322 / 355	329 / 355	373 / 400	435 / 500
	power, idling $p_1 = p_2 = 1,0 \text{ bar}$	\dot{P}_{Leer}	[kW]	68	80	93	108	127	151	154	184	227
	reduced moment of inertia Lp(A) w/o.h./w.h.	J	[kgm ²]	10,6	13,1	15,7	18,9	23,2	28,6	8,79	10,6	13,1
			[dBA]	100 / 80	102 / 81	104 / 82	106 / 84	106 / 84	107 / 85	108 / 86	112 / 87	114 / 88
3,25	flow at inlet	V_1	[m ³ /h]	2382	2833	3236	3711	4279	4923	5029	5687	6582
	compressor speed	nH	[1/min]	3626	4123	4564	5082	5696	6387	6502	7278	8275
	motor speed	nM	[1/min]	1470	1470	1470	1470	1470	2950	2950	2950	2950
	discharge temperature	t_2	[°C]	229	221	216	213	210	208	208	209	210
	power at shaft / motor rating	$\dot{P}_{K/Mot}$	[kW]	185 / 250	211 / 250	235 / 315	264 / 315	299 / 355	341 / 400	348 / 400	396 / 500	460 / 500
	power, idling $p_1 = p_2 = 1,0 \text{ bar}$	\dot{P}_{Leer}	[kW]	68	80	93	108	127	151	154	184	227
	reduced moment of inertia Lp(A) w/o.h./w.h.	J	[kgm ²]	10,6	13,1	15,7	18,9	23,2	28,6	8,79	10,6	13,1
			[dBA]	100 / 80	103 / 82	105 / 83	106 / 84	107 / 85	107 / 85	108 / 86	110 / 87	113 / 88
3,50	flow at inlet	V_1	[m ³ /h]	2357	2809	3211	3687	4255	4899	5005	5694	6589
	compressor speed	nH	[1/min]	3626	4123	4564	5082	5696	6387	6502	7278	8275
	motor speed	nM	[1/min]	1470	1470	1470	1470	1470	2950	2950	2950	2950
	discharge temperature	t_2	[°C]	244	235	229	224	220	218	218	218	220
	power at shaft / motor rating	$\dot{P}_{K/Mot}$	[kW]	196 / 250	223 / 250	248 / 315	278 / 315	314 / 355	357 / 400	365 / 400	416 / 500	485 / 630
	power, idling $p_1 = p_2 = 1,0 \text{ bar}$	\dot{P}_{Leer}	[kW]	68	80	93	108	127	151	154	184	227
	reduced moment of inertia Lp(A) w/o.h./w.h.	J	[kgm ²]	10,6	13,1	15,7	18,9	23,2	28,6	8,79	10,6	13,1
			[dBA]	102 / 81	104 / 82	105 / 84	106 / 84	107 / 85	108 / 85	108 / 86	110 / 87	113 / 88

Performance data based on the compression of air (p₁= 1.0 bar, t₁ = 20 °C)

Discharge pressure p ₂ [bar gauge]	Compressor size gear ratio	VML 95										
		i	i ₈	i ₉	i ₁₀	i ₁₁	i ₁₂	i ₁₃	i ₇	i ₈	i ₈₉	
0,75	flow at inlet	V ₁ [m ³ /h]	2941	3440	3885	4411	5040	5752	5871	6679	7150	
	compressor speed	nH [1/min]	3626	4123	4564	5082	5696	6387	6502	7278	7726	
	motor speed	nM [1/min]	1470	1470	1470	1470	1470	1470	2950	2950	2950	
	discharge temperature	t ₂ [°C]	83	83	83	83	84	86	86	88	90	
	power at shaft / motor rating	P _{K/Mot} [kW]	65 / 90	76 / 110	85 / 110	97 / 132	113 / 132	132 / 160	136 / 160	160 / 200	176 / 200	
	power, idling p ₁ = p ₂ = 1,0 bar	P _{Leer} [kW]	33,8	40	46,4	55,6	66,3	79,6	81	106	119	
	reduced moment of inertia	J [kgm ²]	7,3	8,5	9,6	11	12,7	14,9	6,6	7,3	8,0	
	Lp(A) w/o.h./w.h.	J [dBA]	96 / 75	97 / 78	98 / 79	99 / 80	100 / 81	100 / 83	101 / 83	102 / 83	103 / 84	
	1,00	flow at inlet	V ₁ [m ³ /h]	2894	3393	3838	4364	4992	5705	5824	6632	7103
		compressor speed	nH [1/min]	3626	4123	4564	5082	5696	6387	6502	7278	7726
motor speed		nM [1/min]	1470	1470	1470	1470	1470	1470	2950	2950	2950	
discharge temperature		t ₂ [°C]	101	100	99	98	99	100	100	102	103	
power at shaft / motor rating		P _{K/Mot} [kW]	83 / 110	95 / 132	106 / 132	120 / 160	138 / 160	159 / 200	163 / 200	190 / 250	207 / 250	
power, idling p ₁ = p ₂ = 1,0 bar		P _{Leer} [kW]	33,8	40	46,4	55,6	66,3	79,6	81	106	119	
reduced moment of inertia		J [kgm ²]	7,3	8,5	9,6	11	12,7	14,9	6,6	7,3	8,0	
Lp(A) w/o.h./w.h.		J [dBA]	97 / 76	97 / 78	98 / 79	100 / 80	101 / 81	102 / 84	102 / 84	103 / 84	104 / 84	
1,25		flow at inlet	V ₁ [m ³ /h]	2873	3371	3790	4316	4945	5657	5776	6584	7055
		compressor speed	nH [1/min]	3626	4123	4564	5082	5696	6387	6502	7278	7726
	motor speed	nM [1/min]	1470	1470	1470	1470	1470	1470	2950	2950	2950	
	discharge temperature	t ₂ [°C]	118	117	116	115	114	114	115	116	117	
	power at shaft / motor rating	P _{K/Mot} [kW]	99 / 132	114 / 132	127 / 160	143 / 200	163 / 200	187 / 250	191 / 250	221 / 250	240 / 315	
	power, idling p ₁ = p ₂ = 1,0 bar	P _{Leer} [kW]	40,4	48,3	46,4	55,6	66,3	79,6	81	106	119	
	reduced moment of inertia	J [kgm ²]	7,3	8,5	9,6	11	12,7	14,9	6,6	7,3	8,0	
	Lp(A) w/o.h./w.h.	J [dBA]	98 / 76	99 / 79	100 / 80	101 / 80	102 / 81	103 / 84	103 / 84	104 / 84	105 / 85	
	1,50	flow at inlet	V ₁ [m ³ /h]	2835	3334	3779	4305	4934	5610	5729	6537	7008
		compressor speed	nH [1/min]	3626	4123	4564	5082	5696	6387	6502	7278	7726
motor speed		nM [1/min]	1470	1470	1470	1470	1470	1470	2950	2950	2950	
discharge temperature		t ₂ [°C]	134	131	130	129	130	129	129	130	131	
power at shaft / motor rating		P _{K/Mot} [kW]	113 / 132	130 / 160	146 / 200	165 / 200	189 / 250	215 / 250	220 / 250	252 / 315	272 / 315	
power, idling p ₁ = p ₂ = 1,0 bar		P _{Leer} [kW]	40,4	48,3	57	67,3	80	79,6	81	106	119	
reduced moment of inertia		J [kgm ²]	7,3	8,5	9,6	11	12,7	14,9	6,6	7,3	8,0	
Lp(A) w/o.h./w.h.		J [dBA]	98 / 77	100 / 80	100 / 80	101 / 81	102 / 82	103 / 84	103 / 84	104 / 84	105 / 85	
1,75		flow at inlet	V ₁ [m ³ /h]	2798	3297	3742	4268	4896	5609	5728	6536	6960
		compressor speed	nH [1/min]	3626	4123	4564	5082	5696	6387	6502	7278	7726
	motor speed	nM [1/min]	1470	1470	1470	1470	1470	1470	2950	2950	2950	
	discharge temperature	t ₂ [°C]	150	147	145	144	143	143	143	145	146	
	power at shaft / motor rating	P _{K/Mot} [kW]	127 / 160	146 / 160	163 / 200	184 / 250	210 / 250	241 / 315	246 / 315	285 / 315	305 / 355	
	power, idling p ₁ = p ₂ = 1,0 bar	P _{Leer} [kW]	40,4	48,3	57	67,3	80	96,3	98	152	119	
	reduced moment of inertia	J [kgm ²]	7,3	8,5	9,6	11	12,7	14,9	6,6	7,3	8,0	
	Lp(A) w/o.h./w.h.	J [dBA]	99 / 79	101 / 81	101 / 81	102 / 83	103 / 83	104 / 84	104 / 84	105 / 85	106 / 85	
	2,00	flow at inlet	V ₁ [m ³ /h]	2760	3259	3705	4230	4859	5571	5690	6499	6969
		compressor speed	nH [1/min]	3626	4123	4564	5082	5696	6387	6502	7278	7726
motor speed		nM [1/min]	1470	1470	1470	1470	1470	1470	2950	2950	2950	
discharge temperature		t ₂ [°C]	167	163	160	158	156	156	156	157	158	
power at shaft / motor rating		P _{K/Mot} [kW]	142 / 200	162 / 200	180 / 250	202 / 250	230 / 315	263 / 315	269 / 315	309 / 355	334 / 400	
power, idling p ₁ = p ₂ = 1,0 bar		P _{Leer} [kW]	40,4	48,3	57	67,3	80,3	96,3	98	152	170	
reduced moment of inertia		J [kgm ²]	7,3	8,5	9,6	11	12,7	14,9	6,6	7,3	8,0	
Lp(A) w/o.h./w.h.		J [dBA]	99 / 79	101 / 81	102 / 82	102 / 83	103 / 83	104 / 84	105 / 84	106 / 85	107 / 85	
2,25		flow at inlet	V ₁ [m ³ /h]									
		compressor speed	nH [1/min]									
	motor speed	nM [1/min]										
	discharge temperature	t ₂ [°C]										
	power at shaft / motor rating	P _{K/Mot} [kW]										
	power, idling p ₁ = p ₂ = 1,0 bar	P _{Leer} [kW]										
	reduced moment of inertia	J [kgm ²]										
	Lp(A) w/o.h./w.h.	J [dBA]										
	2,50	flow at inlet	V ₁ [m ³ /h]									
		compressor speed	nH [1/min]									
motor speed		nM [1/min]										
discharge temperature		t ₂ [°C]										
power at shaft / motor rating		P _{K/Mot} [kW]										
power, idling p ₁ = p ₂ = 1,0 bar		P _{Leer} [kW]										
reduced moment of inertia		J [kgm ²]										
Lp(A) w/o.h./w.h.		J [dBA]										
2,75		flow at inlet	V ₁ [m ³ /h]									
		compressor speed	nH [1/min]									
	motor speed	nM [1/min]										
	discharge temperature	t ₂ [°C]										
	power at shaft / motor rating	P _{K/Mot} [kW]										
	power, idling p ₁ = p ₂ = 1,0 bar	P _{Leer} [kW]										
	reduced moment of inertia	J [kgm ²]										
	Lp(A) w/o.h./w.h.	J [dBA]										
	3,00	flow at inlet	V ₁ [m ³ /h]									
		compressor speed	nH [1/min]									
motor speed		nM [1/min]										
discharge temperature		t ₂ [°C]										
power at shaft / motor rating		P _{K/Mot} [kW]										
power, idling p ₁ = p ₂ = 1,0 bar		P _{Leer} [kW]										
reduced moment of inertia		J [kgm ²]										
Lp(A) w/o.h./w.h.		J [dBA]										
3,25		flow at inlet	V ₁ [m ³ /h]									
		compressor speed	nH [1/min]									
	motor speed	nM [1/min]										
	discharge temperature	t ₂ [°C]										
	power at shaft / motor rating	P _{K/Mot} [kW]										
	power, idling p ₁ = p ₂ = 1,0 bar	P _{Leer} [kW]										
	reduced moment of inertia	J [kgm ²]										
	Lp(A) w/o.h./w.h.	J [dBA]										
	3,50	flow at inlet	V ₁ [m ³ /h]									
		compressor speed	nH [1/min]									
motor speed		nM [1/min]										
discharge temperature		t ₂ [°C]										
power at shaft / motor rating		P _{K/Mot} [kW]										
power, idling p ₁ = p ₂ = 1,0 bar		P _{Leer} [kW]										
reduced moment of inertia		J [kgm ²]										
Lp(A) w/o.h./w.h.		J [dBA]										

Performance data based on the compression of air ($p_1 = 1.0 \text{ bar}$, $t_1 = 20 \text{ °C}$)

Discharge pressure p_2 [bar gauge]	Compressor size		VM 140									
	gear ratio		i	i_6	i_7	i_8	i_9	i_{10}	i_{11}	i_5	i_6	i_7
0,75	flow at inlet	V_1	[m ³ /h]									
	compressor speed	nH	[1/min]									
	motor speed	nM	[1/min]									
	discharge temperature	t_2	[°C]									
	power at shaft / motor rating	$\dot{P}_{K/Mot}$	[kW]									
	power, idling $p_1 = p_2 = 1,0 \text{ bar}$	P_{Leer}	[kW]									
	reduced moment of inertia	J	[kgm ²]									
	Lp(A) w.o.h./w.h.		[dBA]									
1,00	flow at inlet	V_1	[m ³ /h]									
	compressor speed	nH	[1/min]									
	motor speed	nM	[1/min]									
	discharge temperature	t_2	[°C]									
	power at shaft / motor rating	$\dot{P}_{K/Mot}$	[kW]									
	power, idling $p_1 = p_2 = 1,0 \text{ bar}$	P_{Leer}	[kW]									
	reduced moment of inertia	J	[kgm ²]									
	Lp(A) w.o.h./w.h.		[dBA]									
1,25	flow at inlet	V_1	[m ³ /h]									
	compressor speed	nH	[1/min]									
	motor speed	nM	[1/min]									
	discharge temperature	t_2	[°C]									
	power at shaft / motor rating	$\dot{P}_{K/Mot}$	[kW]									
	power, idling $p_1 = p_2 = 1,0 \text{ bar}$	P_{Leer}	[kW]									
	reduced moment of inertia	J	[kgm ²]									
	Lp(A) w.o.h./w.h.		[dBA]									
1,50	flow at inlet	V_1	[m ³ /h]									
	compressor speed	nH	[1/min]									
	motor speed	nM	[1/min]									
	discharge temperature	t_2	[°C]									
	power at shaft / motor rating	$\dot{P}_{K/Mot}$	[kW]									
	power, idling $p_1 = p_2 = 1,0 \text{ bar}$	P_{Leer}	[kW]									
	reduced moment of inertia	J	[kgm ²]									
	Lp(A) w.o.h./w.h.		[dBA]									
1,75	flow at inlet	V_1	[m ³ /h]									
	compressor speed	nH	[1/min]									
	motor speed	nM	[1/min]									
	discharge temperature	t_2	[°C]									
	power at shaft / motor rating	$\dot{P}_{K/Mot}$	[kW]									
	power, idling $p_1 = p_2 = 1,0 \text{ bar}$	P_{Leer}	[kW]									
	reduced moment of inertia	J	[kgm ²]									
	Lp(A) w.o.h./w.h.		[dBA]									
2,00	flow at inlet	V_1	[m ³ /h]	4321	4984	5706	6452	7466	8593	8737	9754	10949
	compressor speed	nH	[1/min]	2886	3234	3612	4000	4523	5104	5189	5791	6490
	motor speed	nM	[1/min]	1470	1470	1470	1470	1470	1470	2950	2950	2950
	discharge temperature	t_2	[°C]	149	147	146	146	147	149	150	155	161
	power at shaft / motor rating	$\dot{P}_{K/Mot}$	[kW]	205 / 250	233 / 315	265 / 315	299 / 355	349 / 400	408 / 500	418 / 500	485 / 560	572 / 630
	power, idling $p_1 = p_2 = 1,0 \text{ bar}$	P_{Leer}	[kW]	73	88	108	129	160	196	236	288	357
	reduced moment of inertia	J	[kgm ²]	24,4	29,3	35,1	41,6	51,4	63,5	20,7	24,4	29,3
	Lp(A) w.o.h./w.h.		[dBA]	98 / 79	100 / 80	101 / 81	102 / 82	104 / 84	106 / 85	106 / 85	107 / 85	108 / 85
2,25	flow at inlet	V_1	[m ³ /h]	4279	4941	5664	6410	7423	8551	8694	9711	10906
	compressor speed	nH	[1/min]	2886	3234	3612	4000	4523	5104	5189	5791	6490
	motor speed	nM	[1/min]	1470	1470	1470	1470	1470	2950	2950	2950	2950
	discharge temperature	t_2	[°C]	162	160	159	158	158	160	161	166	172
	power at shaft / motor rating	$\dot{P}_{K/Mot}$	[kW]	224 / 250	254 / 315	288 / 315	325 / 355	377 / 500	440 / 500	450 / 500	521 / 560	611 / 700
	power, idling $p_1 = p_2 = 1,0 \text{ bar}$	P_{Leer}	[kW]	73	88	108	129	160	196	236	288	357
	reduced moment of inertia	J	[kgm ²]	24,4	29,3	35,1	41,6	51,4	63,5	20,7	24,4	29,3
	Lp(A) w.o.h./w.h.		[dBA]	98 / 79	100 / 80	101 / 81	102 / 82	105 / 84	106 / 85	106 / 85	107 / 85	108 / 85
2,50	flow at inlet	V_1	[m ³ /h]	4261	4923	5621	6368	7381	8509	8652	9669	10864
	compressor speed	nH	[1/min]	2886	3234	3612	4000	4523	5104	5189	5791	6490
	motor speed	nM	[1/min]	1470	1470	1470	1470	1470	2950	2950	2950	2950
	discharge temperature	t_2	[°C]	175	173	171	170	173	171	172	176	182
	power at shaft / motor rating	$\dot{P}_{K/Mot}$	[kW]	243 / 315	278 / 315	312 / 355	351 / 400	406 / 500	472 / 560	482 / 560	556 / 630	650 / 700
	power, idling $p_1 = p_2 = 1,0 \text{ bar}$	P_{Leer}	[kW]	104	125	108	129	170	196	236	288	357
	reduced moment of inertia	J	[kgm ²]	24,4	29,3	35,1	41,6	51,4	63,5	20,7	24,4	29,3
	Lp(A) w.o.h./w.h.		[dBA]	99 / 80	101 / 81	101 / 81	103 / 83	106 / 84	107 / 85	107 / 85	108 / 85	109 / 85
2,75	flow at inlet	V_1	[m ³ /h]	4225	4888	5610	6325	7339	8467	8610	9627	10822
	compressor speed	nH	[1/min]	2886	3234	3612	4000	4523	5104	5189	5791	6490
	motor speed	nM	[1/min]	1470	1470	1470	1470	1470	2950	2950	2950	2950
	discharge temperature	t_2	[°C]	187	184	183	182	182	182	183	187	193
	power at shaft / motor rating	$\dot{P}_{K/Mot}$	[kW]	260 / 315	296 / 355	337 / 400	378 / 500	436 / 500	505 / 560	515 / 560	593 / 630	690 / 800
	power, idling $p_1 = p_2 = 1,0 \text{ bar}$	P_{Leer}	[kW]	104	125	150	129	160	196	236	288	357
	reduced moment of inertia	J	[kgm ²]	24,4	29,3	35,1	41,6	51,4	63,5	20,7	24,4	29,3
	Lp(A) w.o.h./w.h.		[dBA]	99 / 80	101 / 81	102 / 82	103 / 83	106 / 84	107 / 85	107 / 85	108 / 85	109 / 85
3,00	flow at inlet	V_1	[m ³ /h]	4190	4852	5575	6321	7334	8424	8567	9584	10779
	compressor speed	nH	[1/min]	2886	3234	3612	4000	4523	5104	5189	5791	6490
	motor speed	nM	[1/min]	1470	1470	1470	1470	1470	2950	2950	2950	2950
	discharge temperature	t_2	[°C]	199	196	194	193	193	194	194	198	204
	power at shaft / motor rating	$\dot{P}_{K/Mot}$	[kW]	277 / 315	314 / 355	357 / 400	402 / 500	467 / 560	538 / 630	549 / 630	630 / 700	731 / 800
	power, idling $p_1 = p_2 = 1,0 \text{ bar}$	P_{Leer}	[kW]	104	125	150	170	220	196	236	288	357
	reduced moment of inertia	J	[kgm ²]	24,4	29,3	35,1	41,6	51,4	63,5	20,7	24,4	29,3
	Lp(A) w.o.h./w.h.		[dBA]	100 / 80	101 / 82	102 / 82	103 / 83	106 / 84	107 / 85	107 / 85	108 / 85	109 / 86
3,25	flow at inlet	V_1	[m ³ /h]	4154	4817	5539	6285	7299	8427	8570	9542	10737
	compressor speed	nH	[1/min]	2886	3234	3612	4000	4523	5104	5189	5791	6490
	motor speed	nM	[1/min]	1470	1470	1470	1470	1470	2950	2950	2950	2950
	discharge temperature	t_2	[°C]	212	208	205	204	203	204	205	210	215
	power at shaft / motor rating	$\dot{P}_{K/Mot}$	[kW]	294 / 355	333 / 400	377 / 500	424 / 500	491 / 560	571 / 630	583 / 630	667 / 800	772 / 900
	power, idling $p_1 = p_2 = 1,0 \text{ bar}$	P_{Leer}	[kW]	104	125	150	170	220	270	343	288	357
	reduced moment of inertia	J	[kgm ²]	24,4	29,3	35,1	41,6	51,4	63,5	20,7	24,4	29,3
	Lp(A) w.o.h./w.h.		[dBA]	100 / 80	102 / 82	103 / 83	104 / 83	106 / 84	108 / 85	108 / 85	108 / 86	109 / 86
3,50	flow at inlet	V_1	[m ³ /h]	4119	4781	5504	6250	7263	8391	8534	9551	10746
	compressor speed	nH	[1/min]	2886	3234	3612	4000	4523	5104	5189	5791	6490
	motor speed	nM	[1/min]	1470	1470	1470	1470	1470	2950	2950	2950	2950
	discharge temperature	t_2	[°C]	225	220	216	214	213	214	214	219	226
	power at shaft / motor rating	$\dot{P}_{K/Mot}$	[kW]	311 / 355	352 / 400	398 / 500	446 / 500	516 / 630	598 / 630	610 / 700	702 / 800	816 / 900
	power, idling $p_1 = p_2 = 1,0 \text{ bar}$	P_{Leer}	[kW]	104	125	150	170	220	270	343	414	506
	reduced moment of inertia	J	[kgm ²]	24,4	29,3	35,1	41,6	51,4	63,5	20,7	24,4	29,3
	Lp(A) w.o.h./w.h.		[dBA]	101 / 81	102 / 83	103 / 83	105 / 84	106 / 84	108 / 85	108 / 85	108 / 86	109 / 86

Performance data based on the compression of air ($p_1= 1.0 \text{ bar}$, $t_1= 20 \text{ °C}$)

Discharge pressure p_2 [bar gauge]	Compressor size gear ratio	VML 150										
		i	i_5	i_6	i_7	i_8	i_9	i_{10}	i_{11}	i_5	i_6	
0,75	flow at inlet	\dot{V}_1 [m³/h]	3980	4586	5224	5981	6960	7836	8870	9139	10408	
	compressor speed	nH [1/min]	2599	2912	3240	3626	4123	4564	5082	5216	5844	
	motor speed	nM [1/min]	1470	1470	1470	1470	1470	1470	1470	1470	2950	
	discharge temperature	t_2 [°C]	84	83	83	82	83	84	85	86	88	
	power at shaft / motor rating	$\dot{P}_{K/Mot}$ [kW]	90 / 110	102 / 132	115 / 132	131 / 160	153 / 200	175 / 200	202 / 250	210 / 250	248 / 315	
	power, idling $p_1 = p_2 = 1,0 \text{ bar}$	\dot{P}_{Leer} [kW]	37,9	44,8	53	63	78	93	112	131	163	
	reduced moment of inertia	J [kgm²]	10,07	12,55	15,58	19,13	24	29,83	36,74	10,07	12,55	
	Lp(A) w/o.h./w.h.	J [dBA]	97 / 78	99 / 80	100 / 80	101 / 81	103 / 82	104 / 83	104 / 83	105 / 84	106 / 85	
	1,00	flow at inlet	\dot{V}_1 [m³/h]	3906	4513	5151	5907	6887	7762	8796	9065	10335
		compressor speed	nH [1/min]	2599	2912	3240	3626	4123	4564	5082	5216	5844
motor speed		nM [1/min]	1470	1470	1470	1470	1470	1470	1470	1470	2950	
discharge temperature		t_2 [°C]	104	101	100	99	98	99	99	100	102	
power at shaft / motor rating		$\dot{P}_{K/Mot}$ [kW]	115 / 132	129 / 160	144 / 200	163 / 200	189 / 250	214 / 250	245 / 315	253 / 315	295 / 355	
power, idling $p_1 = p_2 = 1,0 \text{ bar}$		\dot{P}_{Leer} [kW]	37,9	44,8	53	63	78	93	112	131	163	
reduced moment of inertia		J [kgm²]	10,07	12,55	15,58	19,13	24	29,83	36,74	10,07	12,55	
Lp(A) w/o.h./w.h.		J [dBA]	98 / 79	100 / 80	102 / 81	103 / 82	104 / 83	105 / 84	106 / 84	107 / 84	108 / 85	
1,25		flow at inlet	\dot{V}_1 [m³/h]	3873	4480	5118	5834	6813	7688	8722	8991	10261
		compressor speed	nH [1/min]	2599	2912	3240	3626	4123	4564	5082	5216	5844
	motor speed	nM [1/min]	1470	1470	1470	1470	1470	1470	1470	1470	2950	
	discharge temperature	t_2 [°C]	120	118	117	116	114	114	114	114	116	
	power at shaft / motor rating	$\dot{P}_{K/Mot}$ [kW]	136 / 160	153 / 200	173 / 200	196 / 250	225 / 250	253 / 315	287 / 315	297 / 355	343 / 400	
	power, idling $p_1 = p_2 = 1,0 \text{ bar}$	\dot{P}_{Leer} [kW]	59	70	82	98	120	142	170	192	235	
	reduced moment of inertia	J [kgm²]	10,07	12,55	15,58	19,13	24	29,83	36,74	10,07	12,55	
	Lp(A) w/o.h./w.h.	J [dBA]	99 / 80	101 / 81	103 / 82	104 / 83	105 / 84	106 / 85	106 / 85	107 / 85	108 / 86	
	1,50	flow at inlet	\dot{V}_1 [m³/h]	3815	4422	5060	5816	6796	7671	8649	8917	10187
		compressor speed	nH [1/min]	2599	2912	3240	3626	4123	4564	5082	5216	5844
motor speed		nM [1/min]	1470	1470	1470	1470	1470	1470	1470	1470	2950	
discharge temperature		t_2 [°C]	137	133	131	130	129	129	129	129	130	
power at shaft / motor rating		$\dot{P}_{K/Mot}$ [kW]	156 / 200	176 / 200	197 / 250	224 / 250	260 / 315	293 / 355	331 / 400	341 / 400	392 / 500	
power, idling $p_1 = p_2 = 1,0 \text{ bar}$		\dot{P}_{Leer} [kW]	59	70	82	98	120	142	170	192	235	
reduced moment of inertia		J [kgm²]	10,07	12,55	15,58	19,13	24	29,83	36,74	10,07	12,55	
Lp(A) w/o.h./w.h.		J [dBA]	103 / 83	104 / 83	105 / 83	105 / 83	105 / 84	106 / 85	107 / 85	108 / 85	109 / 86	
1,75		flow at inlet	\dot{V}_1 [m³/h]	3757	4364	5002	5758	6738	7613	8647	8916	10186
		compressor speed	nH [1/min]	2599	2912	3240	3626	4123	4564	5082	5216	5844
	motor speed	nM [1/min]	1470	1470	1470	1470	1470	1470	1470	1470	2950	
	discharge temperature	t_2 [°C]	154	150	146	144	143	142	142	143	144	
	power at shaft / motor rating	$\dot{P}_{K/Mot}$ [kW]	176 / 200	198 / 250	221 / 250	250 / 315	289 / 315	325 / 355	370 / 400	382 / 500	442 / 500	
	power, idling $p_1 = p_2 = 1,0 \text{ bar}$	\dot{P}_{Leer} [kW]	59	70	82	98	120	142	170	192	235	
	reduced moment of inertia	J [kgm²]	10,07	12,55	15,58	19,13	24	29,83	36,74	10,07	12,55	
	Lp(A) w/o.h./w.h.	J [dBA]	103 / 82	104 / 83	105 / 83	106 / 85	106 / 85	107 / 85	108 / 86	108 / 86	109 / 87	
	2,00	flow at inlet	\dot{V}_1 [m³/h]	3699	4305	4944	5700	6679	7555	8589	8858	10127
		compressor speed	nH [1/min]	2599	2912	3240	3626	4123	4564	5082	5216	5844
motor speed		nM [1/min]	1470	1470	1470	1470	1470	1470	1470	1470	2950	
discharge temperature		t_2 [°C]	172	166	162	159	156	155	155	155	156	
power at shaft / motor rating		$\dot{P}_{K/Mot}$ [kW]	197 / 250	220 / 250	246 / 315	277 / 315	318 / 355	357 / 400	405 / 500	418 / 500	480 / 560	
power, idling $p_1 = p_2 = 1,0 \text{ bar}$		\dot{P}_{Leer} [kW]	59	70	82	98	120	142	170	192	235	
reduced moment of inertia		J [kgm²]	10,07	12,55	15,58	19,13	24	29,83	36,74	10,07	12,55	
Lp(A) w/o.h./w.h.		J [dBA]	103 / 82	104 / 83	105 / 83	106 / 85	107 / 85	108 / 86	109 / 86	109 / 87	111 / 87	
2,25		flow at inlet	\dot{V}_1 [m³/h]									
		compressor speed	nH [1/min]									
	motor speed	nM [1/min]										
	discharge temperature	t_2 [°C]										
	power at shaft / motor rating	$\dot{P}_{K/Mot}$ [kW]										
	power, idling $p_1 = p_2 = 1,0 \text{ bar}$	\dot{P}_{Leer} [kW]										
	reduced moment of inertia	J [kgm²]										
	Lp(A) w/o.h./w.h.	J [dBA]										
	2,50	flow at inlet	\dot{V}_1 [m³/h]									
		compressor speed	nH [1/min]									
motor speed		nM [1/min]										
discharge temperature		t_2 [°C]										
power at shaft / motor rating		$\dot{P}_{K/Mot}$ [kW]										
power, idling $p_1 = p_2 = 1,0 \text{ bar}$		\dot{P}_{Leer} [kW]										
reduced moment of inertia		J [kgm²]										
Lp(A) w/o.h./w.h.		J [dBA]										
2,75		flow at inlet	\dot{V}_1 [m³/h]									
		compressor speed	nH [1/min]									
	motor speed	nM [1/min]										
	discharge temperature	t_2 [°C]										
	power at shaft / motor rating	$\dot{P}_{K/Mot}$ [kW]										
	power, idling $p_1 = p_2 = 1,0 \text{ bar}$	\dot{P}_{Leer} [kW]										
	reduced moment of inertia	J [kgm²]										
	Lp(A) w/o.h./w.h.	J [dBA]										
	3,00	flow at inlet	\dot{V}_1 [m³/h]									
		compressor speed	nH [1/min]									
motor speed		nM [1/min]										
discharge temperature		t_2 [°C]										
power at shaft / motor rating		$\dot{P}_{K/Mot}$ [kW]										
power, idling $p_1 = p_2 = 1,0 \text{ bar}$		\dot{P}_{Leer} [kW]										
reduced moment of inertia		J [kgm²]										
Lp(A) w/o.h./w.h.		J [dBA]										
3,25		flow at inlet	\dot{V}_1 [m³/h]									
		compressor speed	nH [1/min]									
	motor speed	nM [1/min]										
	discharge temperature	t_2 [°C]										
	power at shaft / motor rating	$\dot{P}_{K/Mot}$ [kW]										
	power, idling $p_1 = p_2 = 1,0 \text{ bar}$	\dot{P}_{Leer} [kW]										
	reduced moment of inertia	J [kgm²]										
	Lp(A) w/o.h./w.h.	J [dBA]										
	3,50	flow at inlet	\dot{V}_1 [m³/h]									
		compressor speed	nH [1/min]									
motor speed		nM [1/min]										
discharge temperature		t_2 [°C]										
power at shaft / motor rating		$\dot{P}_{K/Mot}$ [kW]										
power, idling $p_1 = p_2 = 1,0 \text{ bar}$		\dot{P}_{Leer} [kW]										
reduced moment of inertia		J [kgm²]										
Lp(A) w/o.h./w.h.		J [dBA]										

Performance data based on the compression of air ($p_1 = 1.0 \text{ bar}$, $t_1 = 20 \text{ °C}$)

Discharge pressure p_2 [bar gauge]	Compressor size gear ratio	VML 250									
		i_1 [-]	i_2	i_3	i_4	i_5	i_6	i_7	i_8	i_9	
0,75	flow at inlet	\dot{V}_1 [m ³ /h]	5761	6677	7698	8761	9985	11417	12980	14598	
	compressor speed	nH [1/min]	1843	2071	2324	2586	2886	3234	3612	4000	
	motor speed	nM [1/min]	1470	1470	1470	1470	1470	1470	1470	1470	
	discharge temperature	t_2 [°C]	85	84	83	82	82	83	84	85	
	power at shaft / motor rating	$\dot{P}_{K/Mot}$ [kW]	132 / 160	149 / 200	169 / 200	191 / 250	217 / 250	250 / 315	289 / 315	333 / 400	
	power, idling $p_1 = p_2 = 1,0 \text{ bar}$	P_{Leer} [kW]	51	61	73	87	104	126	153	185	
	reduced moment of inertia	J [kgm ²]	15,61	19,27	23,68	29,02	35,84	44,69	54,96	68,75	
	Lp(A) w/o.h./w.h.	[dBA]	97 / 79	98 / 80	100 / 82	102 / 83	104 / 84	105 / 85	106 / 85	107 / 85	
	1,00	flow at inlet	\dot{V}_1 [m ³ /h]	5683	6559	7581	8643	9868	11299	12863	14481
compressor speed		nH [1/min]	1843	2071	2324	2586	2886	3234	3612	4000	
motor speed		nM [1/min]	1470	1470	1470	1470	1470	1470	1470	1470	
discharge temperature		t_2 [°C]	105	103	101	99	98	98	98	99	
power at shaft / motor rating		$\dot{P}_{K/Mot}$ [kW]	168 / 200	190 / 250	214 / 250	240 / 315	271 / 315	309 / 355	353 / 400	402 / 500	
power, idling $p_1 = p_2 = 1,0 \text{ bar}$		P_{Leer} [kW]	80	61	73	87	104	126	153	185	
reduced moment of inertia		J [kgm ²]	15,61	19,27	23,68	29,02	35,84	44,69	54,96	68,75	
Lp(A) w/o.h./w.h.		[dBA]	98 / 80	99 / 80	100 / 82	103 / 83	105 / 84	106 / 85	108 / 86	109 / 86	
1,25		flow at inlet	\dot{V}_1 [m ³ /h]	5591	6507	7528	8591	9750	11182	12745	14363
	compressor speed	nH [1/min]	1843	2071	2324	2586	2886	3234	3612	4000	
	motor speed	nM [1/min]	1470	1470	1470	1470	1470	1470	1470	1470	
	discharge temperature	t_2 [°C]	121	119	117	116	115	114	114	114	
	power at shaft / motor rating	$\dot{P}_{K/Mot}$ [kW]	199 / 250	225 / 250	256 / 315	288 / 315	325 / 355	368 / 400	417 / 500	472 / 630	
	power, idling $p_1 = p_2 = 1,0 \text{ bar}$	P_{Leer} [kW]	80	96	115	137	163	196	235	280	
	reduced moment of inertia	J [kgm ²]	15,61	19,27	23,68	29,02	35,84	44,69	54,96	68,75	
	Lp(A) w/o.h./w.h.	[dBA]	98 / 80	99 / 81	101 / 82	103 / 83	105 / 84	106 / 85	108 / 85	110 / 86	
	1,50	flow at inlet	\dot{V}_1 [m ³ /h]	5498	6414	7436	8498	9723	11154	12718	14245
compressor speed		nH [1/min]	1843	2071	2324	2586	2886	3234	3612	4000	
motor speed		nM [1/min]	1470	1470	1470	1470	1470	1470	1470	1470	
discharge temperature		t_2 [°C]	139	135	132	130	129	129	129	129	
power at shaft / motor rating		$\dot{P}_{K/Mot}$ [kW]	229 / 315	259 / 315	292 / 315	328 / 355	371 / 500	424 / 500	485 / 630	542 / 630	
power, idling $p_1 = p_2 = 1,0 \text{ bar}$		P_{Leer} [kW]	80	96	115	137	163	196	235	280	
reduced moment of inertia		J [kgm ²]	15,61	19,27	23,68	29,02	35,84	44,69	54,96	68,75	
Lp(A) w/o.h./w.h.		[dBA]	99 / 81	100 / 82	102 / 83	103 / 83	105 / 84	106 / 85	108 / 85	110 / 87	
1,75		flow at inlet	\dot{V}_1 [m ³ /h]	5405	6322	7343	8406	9630	11062	12625	14243
	compressor speed	nH [1/min]	1843	2071	2324	2586	2886	3234	3612	4000	
	motor speed	nM [1/min]	1470	1470	1470	1470	1470	1470	1470	1470	
	discharge temperature	t_2 [°C]	157	152	148	145	143	142	142	142	
	power at shaft / motor rating	$\dot{P}_{K/Mot}$ [kW]	260 / 315	292 / 315	329 / 355	368 / 400	415 / 500	472 / 630	537 / 630	607 / 710	
	power, idling $p_1 = p_2 = 1,0 \text{ bar}$	P_{Leer} [kW]	80	96	115	137	163	196	235	280	
	reduced moment of inertia	J [kgm ²]	15,61	19,27	23,68	29,02	35,84	44,69	54,96	68,75	
	Lp(A) w/o.h./w.h.	[dBA]	100 / 82	101 / 83	102 / 84	104 / 84	106 / 85	107 / 85	109 / 87	110 / 87	
	2,00	flow at inlet	\dot{V}_1 [m ³ /h]	5313	6229	7251	8313	9538	10969	12533	14150
compressor speed		nH [1/min]	1843	2071	2324	2586	2886	3234	3612	4000	
motor speed		nM [1/min]	1470	1470	1470	1470	1470	1470	1470	1470	
discharge temperature		t_2 [°C]	176	170	164	161	158	156	154	154	
power at shaft / motor rating		$\dot{P}_{K/Mot}$ [kW]	291 / 315	326 / 355	366 / 400	409 / 500	459 / 500	520 / 630	589 / 630	664 / 710	
power, idling $p_1 = p_2 = 1,0 \text{ bar}$		P_{Leer} [kW]	80	96	115	137	163	196	235	280	
reduced moment of inertia		J [kgm ²]	15,61	19,27	23,68	29,02	35,84	44,69	54,96	68,75	
Lp(A) w/o.h./w.h.		[dBA]	101 / 83	102 / 84	103 / 85	104 / 84	107 / 85	108 / 86	109 / 87	109 / 87	
2,25		flow at inlet	\dot{V}_1 [m ³ /h]								
	compressor speed	nH [1/min]									
	motor speed	nM [1/min]									
	discharge temperature	t_2 [°C]									
	power at shaft / motor rating	$\dot{P}_{K/Mot}$ [kW]									
	power, idling $p_1 = p_2 = 1,0 \text{ bar}$	P_{Leer} [kW]									
	reduced moment of inertia	J [kgm ²]									
	Lp(A) w/o.h./w.h.	[dBA]									
	2,50	flow at inlet	\dot{V}_1 [m ³ /h]								
compressor speed		nH [1/min]									
motor speed		nM [1/min]									
discharge temperature		t_2 [°C]									
power at shaft / motor rating		$\dot{P}_{K/Mot}$ [kW]									
power, idling $p_1 = p_2 = 1,0 \text{ bar}$		P_{Leer} [kW]									
reduced moment of inertia		J [kgm ²]									
Lp(A) w/o.h./w.h.		[dBA]									
2,75		flow at inlet	\dot{V}_1 [m ³ /h]								
	compressor speed	nH [1/min]									
	motor speed	nM [1/min]									
	discharge temperature	t_2 [°C]									
	power at shaft / motor rating	$\dot{P}_{K/Mot}$ [kW]									
	power, idling $p_1 = p_2 = 1,0 \text{ bar}$	P_{Leer} [kW]									
	reduced moment of inertia	J [kgm ²]									
	Lp(A) w/o.h./w.h.	[dBA]									
	3,00	flow at inlet	\dot{V}_1 [m ³ /h]								
compressor speed		nH [1/min]									
motor speed		nM [1/min]									
discharge temperature		t_2 [°C]									
power at shaft / motor rating		$\dot{P}_{K/Mot}$ [kW]									
power, idling $p_1 = p_2 = 1,0 \text{ bar}$		P_{Leer} [kW]									
reduced moment of inertia		J [kgm ²]									
Lp(A) w/o.h./w.h.		[dBA]									
3,25		flow at inlet	\dot{V}_1 [m ³ /h]								
	compressor speed	nH [1/min]									
	motor speed	nM [1/min]									
	discharge temperature	t_2 [°C]									
	power at shaft / motor rating	$\dot{P}_{K/Mot}$ [kW]									
	power, idling $p_1 = p_2 = 1,0 \text{ bar}$	P_{Leer} [kW]									
	reduced moment of inertia	J [kgm ²]									
	Lp(A) w/o.h./w.h.	[dBA]									
	3,50	flow at inlet	\dot{V}_1 [m ³ /h]								
compressor speed		nH [1/min]									
motor speed		nM [1/min]									
discharge temperature		t_2 [°C]									
power at shaft / motor rating		$\dot{P}_{K/Mot}$ [kW]									
power, idling $p_1 = p_2 = 1,0 \text{ bar}$		P_{Leer} [kW]									
reduced moment of inertia		J [kgm ²]									
Lp(A) w/o.h./w.h.		[dBA]									

**Sizes - DELTA SCREW - VML 18 R - VML 40 R
VM 8 R - VM 37 R**

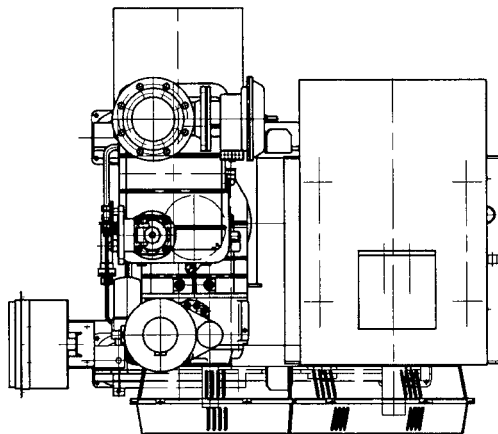
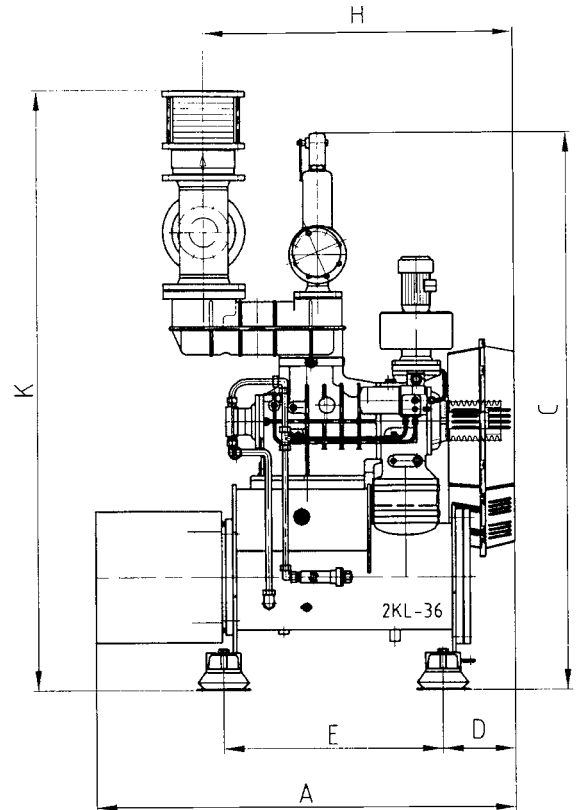
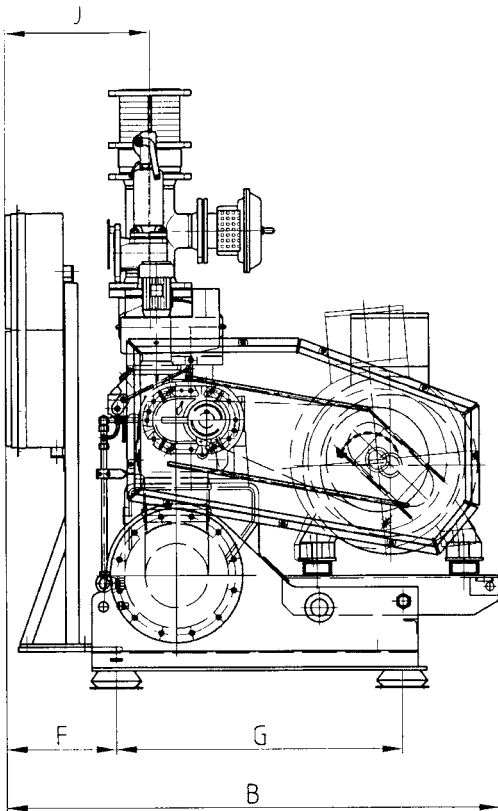

- Instrument panel VMR
 A fault indicator
 B operating hour meter
 C discharge temperature
 D oil temperature
 E discharge pressure
 F oil pressure
 G maintenance indicator
 air filter

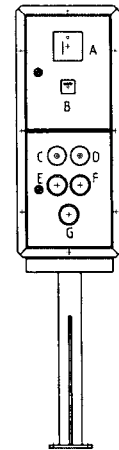

Dimensions without engagement !

size	A	B	C	D	E	F	G	H	J	K	DN DS	PN	oil filling in litres	weight in kg without motor
VML 18 R	990	1430	1542	320	500	382	750	679	863	1743	80	16	8	600
VML 25 R	1274	1610	1802	357	654	380	750	1086	392	2112	125	16	21	800
VML 40 R	1579	1756	2084	325	759	380	990	1170	572	2199	150	16	32	950
VM 8 R	1175	1375	1368	337	525	335	850	861	480	1242	65	16	20	620
VM 15 R	1222	1610	1678	375	584	380	750	950	412	1368 1659*	65	16	26	650
VM 21 R	1292	1610	1678	375	654	380	750	1000	412	1403 1728*	80	16	30	850
VM 37 R	1551	1705	1905	250	759	380	990	1170	572	1876 2335*	150	16	38	1000

* with start-up unloading device

**Sizes - DELTA SCREW - VML 18 R - VML 40 R
VM 8 R - VM 37 R**

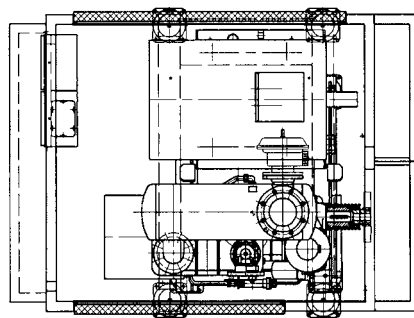
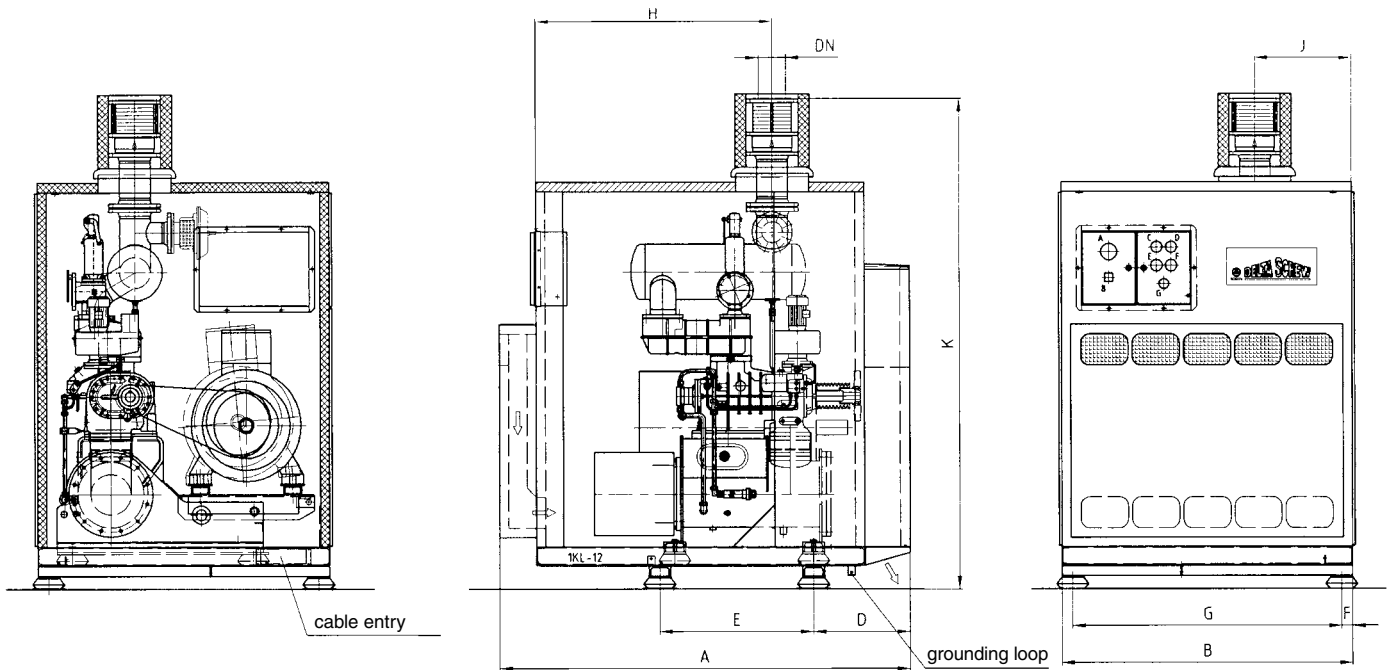

- Instrument panel VMR
 A fault indicator
 B operating hour meter
 C discharge temperature
 D oil temperature
 E discharge pressure
 F oil pressure
 G maintenance indicator air filter

Dimensions without engagement !

size	A	B	C	D	E	F	G	H	J	K	DN DS	PN	oil filling in litres	weight in kg without motor
VML 18 R**	1605	1250	1570	330	1090	130	845	531	661	1908	80	16	8	850
VML 25 R	1910	1600	2100	529	741	60	1480	430	320	2261	125	16	21	1300
VML 40 R	2350	1700	2350	579	841	60	1580	667	358	2516	150	16	32	1500
VM 8 R	1605	1250	1575	330	1090	200	850	746	483	1675	65	16	20	1120
VM 15 R	1825	1500	1900	537	700	60	1380	1019	523	2027	65	16	26	1150
VM 21 R	1910	1600	2100	529	741	60	1480	1055	540	2270	80	16	30	1350
VM 37 R	2350	1700	2350	579	841	60	1580	1297	663	2516	150	16	38	1550

** second silencer outside the acoustic hood

**Sizes - DELTA SCREW - VML 60 - VML 95
VM 45 - VM 75**

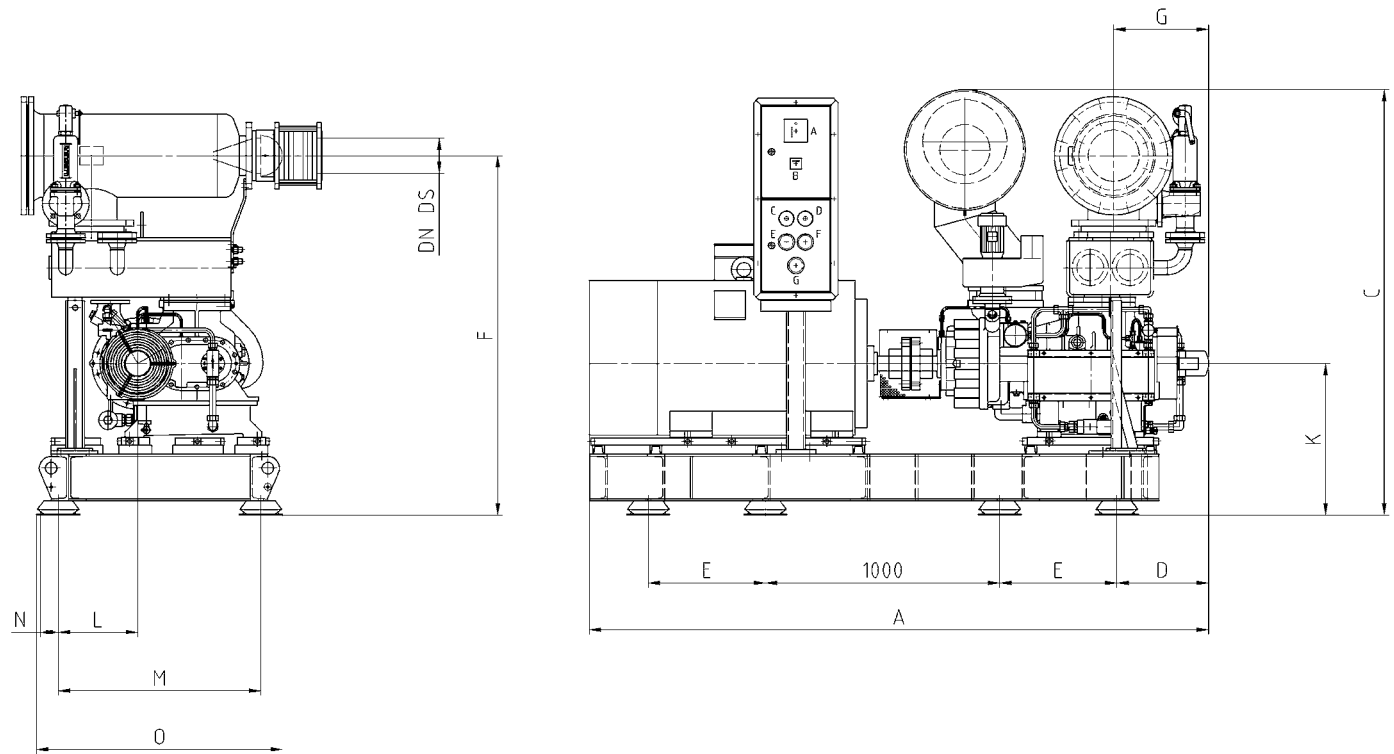

- Instrument panel VMR
 A fault indicator
 B operating hour meter
 C discharge temperature
 D oil temperature
 E discharge pressure
 F oil pressure
 G maintenance indicator air filter

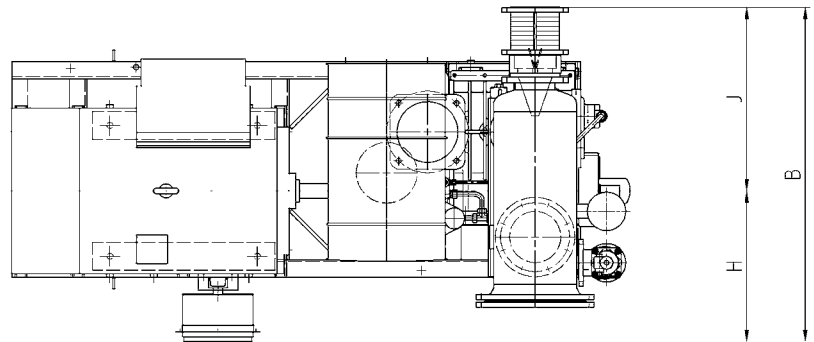

Dimensions without engagement !

size	A	B	C	D	E	F	G	H	J	K	L	M	N	O	DN DS	PN	weight in kg without motor
VM 45	2643	1432	1817	391	500	1534	405	645	787	647	340	865	75	1049	150	16	1490
VML 60	2643	1452	1817	391	500	1534	405	645	807	647	340	865	75	1049	200	10	1470
VM 75	3098	1804	2130	433	700	1768	428	701	1103	730	391	1040	75	1224	200	10	2550
VML 95	3098	1827	2130	433	700	1768	428	701	1126	730	391	1040	75	1224	250	10	2520

**Sizes - DELTA SCREW - VML 60 - VML 95
VM 45 - VM 75**

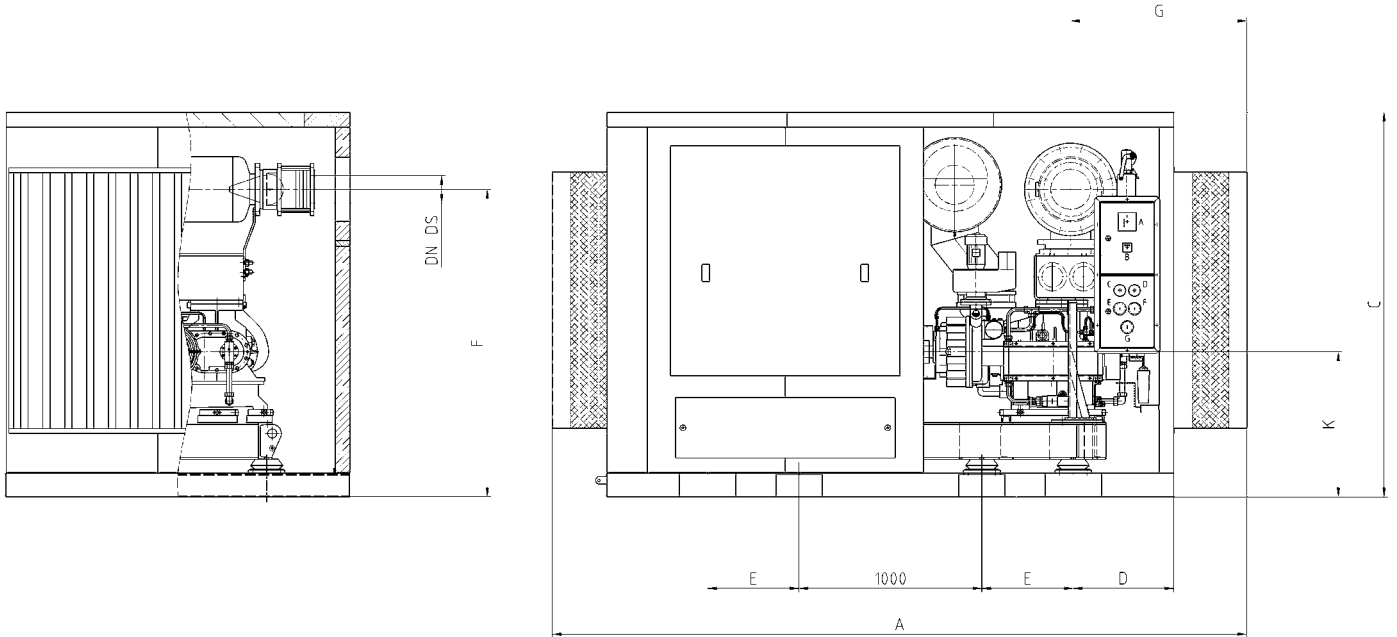

Instrument panel VMR

- A fault indicator
- B operating hour meter
- C discharge temperature
- D oil temperature
- E discharge pressure
- F oil pressure
- G maintenance indicator air filter

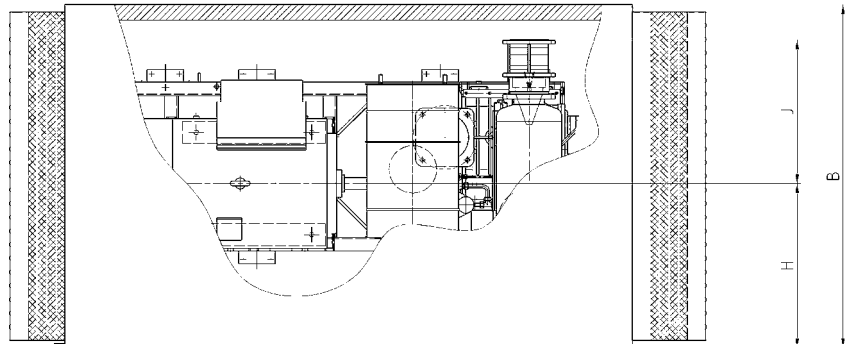

Dimensions without engagement !

size	A	B	C	D	E	F	G	H	J	K	DN DS	PN	weight in kg without motor
VM 45	3800	1880	2100	550	500	1680	964	900	787	793	150	16	2820
VML 60	3800	1880	2100	550	500	1680	964	900	807	793	200	10	2850
VM 75	4350	1960	2375	720	700	1914	1117	891	1374	876	200	10	4020
VML 95	4350	1960	2375	720	700	1914	1117	891	1367	876	250	10	4000

Sizes - DELTA SCREW - VM 85 and VM 140

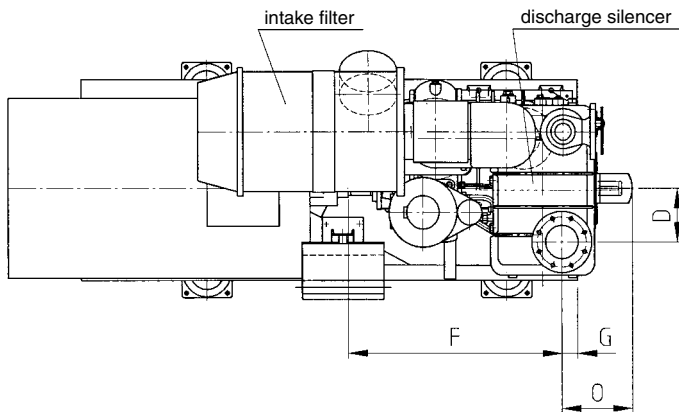
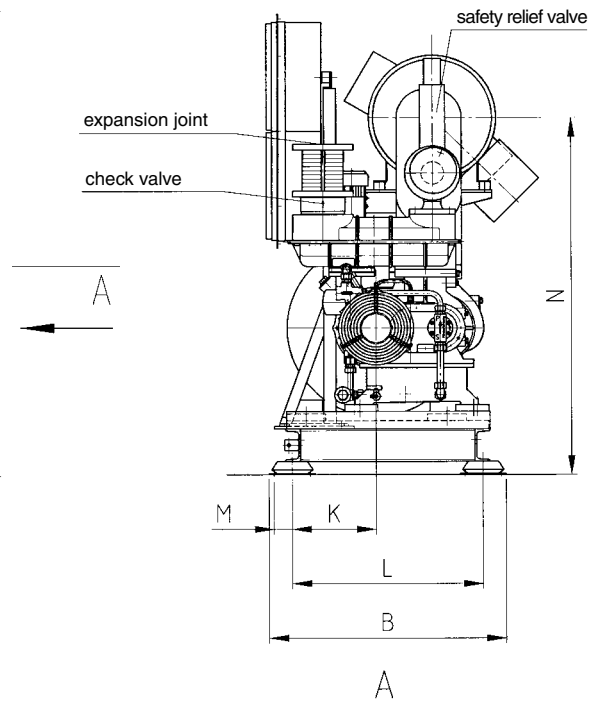
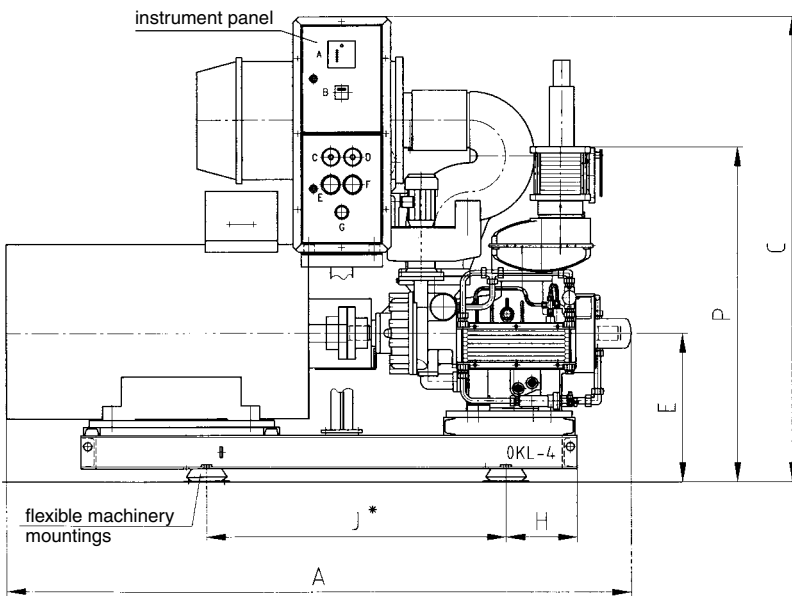

- Instrument panel VMR
 A fault indicator
 B operating hour meter
 C discharge temperature
 D oil temperature
 E discharge pressure
 F oil pressure
 G maintenance indicator air filter

Dimensions without engagement !

size	A*	B	C	D	E	F	G	H	J*	K	L	M	N	O	P	DN DS	PN	DN** DS	PN	weight in kg without motor
VM 85	3265	1485	2010	267	735	1203	86	150	2x1000	415	1130	75	1750	558	2123	200	10	300	10	3220
VM 140	3720	1730	3050	195	950	1384	151	150	3x950	400	1300	75	1990	455	2802	250	10	350	10	5250

* size depending on driving motor (in chart: max. motor)

** nominal width of bare shaft compressor

Sizes - DELTA SCREW - VM 85 and VM 140

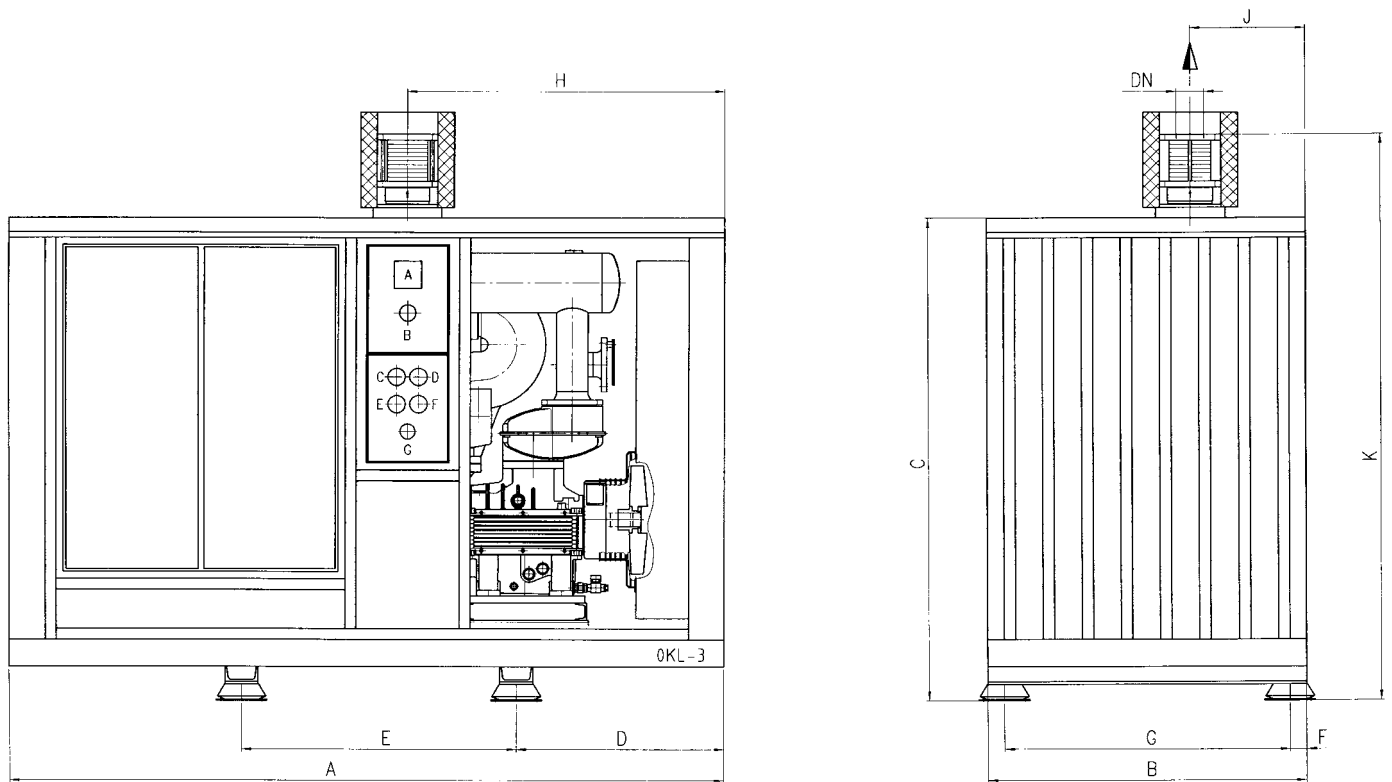

Instrument panel VMR

- A fault indicator
- B operating hour meter
- C discharge temperature
- D oil temperature
- E discharge pressure
- F oil pressure
- G maintenance indicator air filter

Dimensions without engagement !

size	A*	B	C	D	E	F	G	H	J	K	DN DS	PN	oil filling in litres	weight in kg without motor	swivelling range of the doors
VM 85	4000	1775	2310	875	2x1000*	60	1655	981	534	2650	200	10	50	6000	1000
VM 140	4350	2000	2650	900	3x850*	70	1860	901	605	3500	250	10	65	8500	900

* size depending on driving motor (in chart: max. motor)

Sizes VML 150 - VML 250

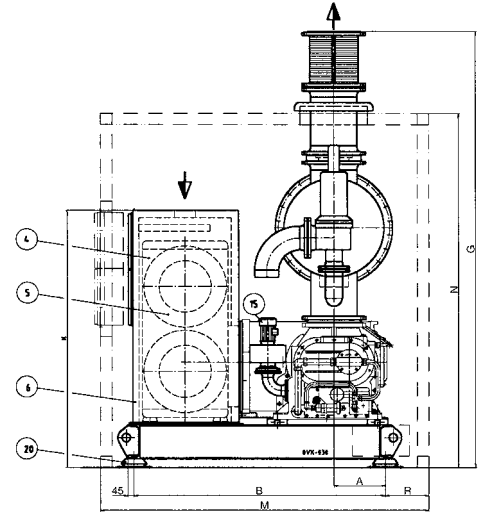
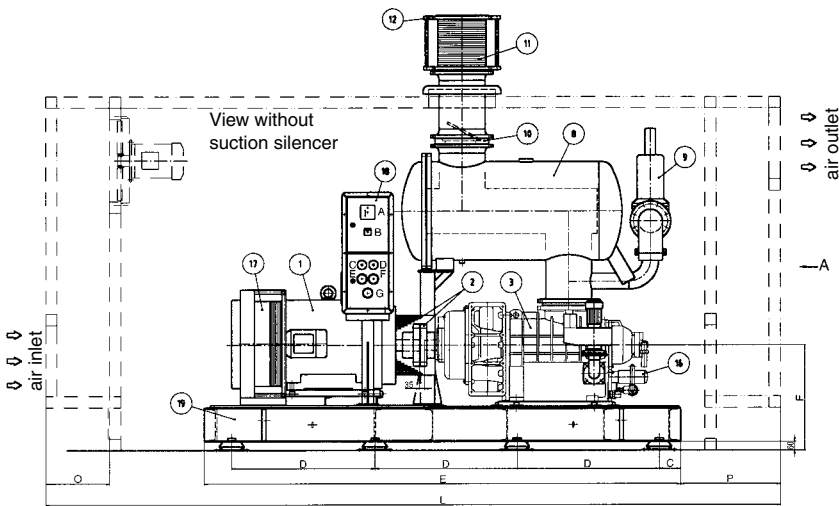

view A

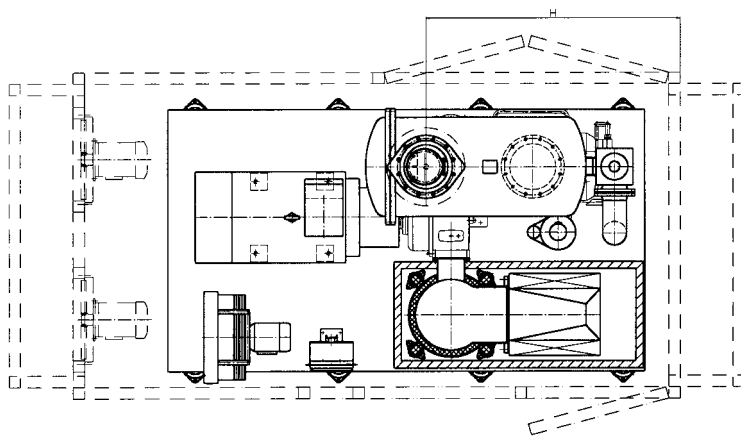

ATTENTION!
Overall dimensions
depending on size of motor

Instrument panel

- A fault indicator *
- B operating hour meter *
- C discharge temperature *
- D oil temperature *
- E discharge pressure
- F oil pressure
- G air intake filter maintenance

- 1. driving motor
- 2. coupling and coupling guard
- 3. compressor
- 4. intake silencer
- 5. air filter
- 6. sound dampening
- 8. discharge silencer
- 9. safety relief valve
- 10. non-return valve

- 11. axial compensator
- 12. connection flange discharge side
- 13. connection flange safety relief valve
- 15. oil mist separator
- 16. oil filter
- 17. oil cooler
- 18. instrument cabinet
- 19. base frame
- 20. flexible machinery mountings

* only upon request

Dimensions without engagement !

size	A	B	C	D	E	F	G	H	K	L	M	N	O	P	R	DN	oil filling in litres	weight approx. kg without motor and acoustic hood
VML 150	360	1760	150	1000	3340	740	x 2693 2923	1785	1815	5150	2300	2500	450	700	305	300	45	5000
VML 250	455	2020	200	1000	4000	950	x 3000 3500	1950	2500	5500	2600	3000	450	700	290	400	90	7100

x Dimensions without acoustic hood



Aerzener Maschinenfabrik GmbH

Reherweg 28 · 31855 Aerzen / Germany – P.O. Box 1163 · 31849 Aerzen / Germany

Phone ++ 49 51 54 / 8 10 · Fax ++ 49 51 54 / 8 11 91 · <http://www.aerzener.com> · E-mail: info@aerzener.de